

# DEN UNGE PILEGRIM

musikk Bertil Palmar Johansen

tekst Terje Nordby



En bestilling fra Olavsfestdagene

2012- Trondheim

# DEN UNGE PILEGRIM

musikk Bertil Palmar Johansen

tekst Terje Nordby

- 1 Se etter hellige tegn
- 2 På vei til Abrahams grav
- 3 Hvem tenner alle himlens lys
- 4 Ild over min by
- 5 Jerusalem
- 6 Drømmene i oss
- 7 Moria
- 8 Sterkeste grenen
- 9 Isak er vår bror
- 10 El Pelegrino
- 11 Lux illuxit
- 12 Ilden er tent
- 13 Se det er dag
- 14 Hver vår stamme
- 15 Reisen er målet ditt
- 16 De samme stjernene
- 17 Lux
- 18 Gutten står og smiler
- 19 Ung jasmin
- 20 Vi har forandret våre mål
- 21 Flor del Mirto
- 22 Vi må fremover
- 23 Abrahams barn – sluttsalme.

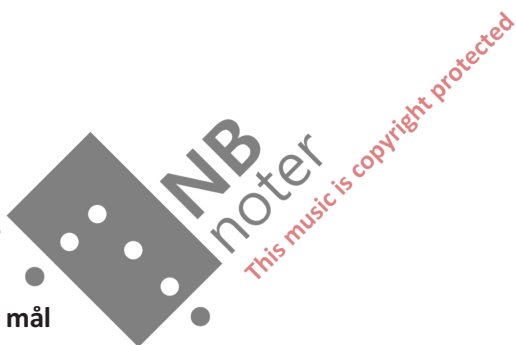

En bestilling fra Olavsfestdagene – 2012 Trondheim

Støttet av Det Norske Komponistfond, Fritt Ord og Olavsfestdagene

# DEN UNGE PILEGRIM

Musikk Bertil Palmar Johansen

Tekst Terje Nordby

Sopran	Anna
Mezzosopran	Esther
Tenor	Abdullah

## Besetning

Fløyte, kromhorn

Klarinett i Bb

Gitar

Tar (solo i og mellom deler – Tar i orkester valgfritt)

Synth

Accordion

Damekor og tre solister fra koret

Slagverk - 4 p. (perc. 5 impro. optional)

Fiolin A ( også vokal – vuggesang f. eks jødisk)

Fiolin B (også vokal og sekkepipe (sabouna) – impro. og vuggesang f.eks gresk)

Strykekvintett – vl.1, vl.2, vla, vcl og cb

blank



# Se etter hellige tegn del 1

Musikk Bertil Palmar Johansen  
Tekst Terje Nordby

♩ = 66

Flute *mf*

Clarinet in B $\flat$

Guitar

Tar

Synth. *p* synth-string

Accordion *mp*

Tubular Bells *mf* To Tub. B.

Anna/Esther

Abdullah

Violin A. *p*

Viol. +div *p*

Violin 1 *mf*

Violin 2 *p*

Viola *p*

Violoncello *p*

Contrabass *p*

The musical score is for the piece 'Se etter hellige tegn del 1'. It is in 4/4 time with a tempo of 66 beats per minute. The key signature has one flat (B-flat). The score includes parts for Flute, Clarinet in B-flat, Guitar, Tar, Synth. (with synth-string), Accordion, Tubular Bells, Anna/Esther, Abdullah, Violin A., Viol. +div, Violin 1, Violin 2, Viola, Violoncello, and Contrabass. Dynamics range from piano (p) to mezzo-forte (mf). The flute and violin 1 parts feature a triplet of eighth notes. A watermark for 'NB noter' is visible across the center of the page.

8

Fl.

Cl.

Gtr.

Tar.

Synth

Accord.

Tub. B.

A/E

Abd.

Vln. A

Vln.+div

Vln. 1

Vln. 2

Vla.

Vc.

Cb.

**NB**  
noter  
This music is copyright protected



Fl. 

Cl. 

Gtr. 

Tar. 

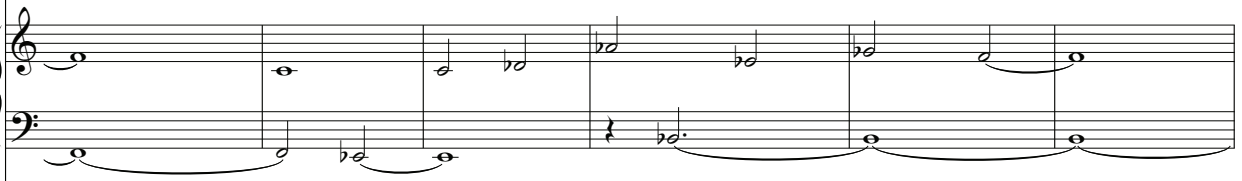
Synth 

Accord. 

Vib. 

A/E   
 lengt - ter et - ter sje - le fred. Bry-te opp med alt jeg har som den sto - re A - bra-ham,

Abd. 

Vln. A   
*mp*

Vln.+div   
*p*

Vln. 1   
*mp*

Vln. 2 

Vla. 

Vc. 

Cb. 

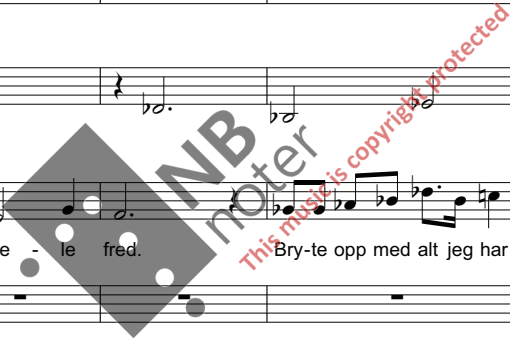



27

Fl.

Cl.

Gtr.

Tar.

Synth

Accord.

Vib.

AE

Abd.

Vln. A

Vln.+div

Vln. 1

Vln. 2

Vla.

Vc.

Cb.



34

Fl.

Cl.

Gtr.

Tar.

Synth

Accord.

Tub. B.

A/E

Abd. 

fat-tig-dom og bom-ber. Pile-grim-en ser et-ter hel-li-ge tegn. Bry-te opp med alt jeg har som den klo-ke

Vln. A

Vln.+div

Vln. 1

Vln. 2

Vla.

Vc.

Cb.

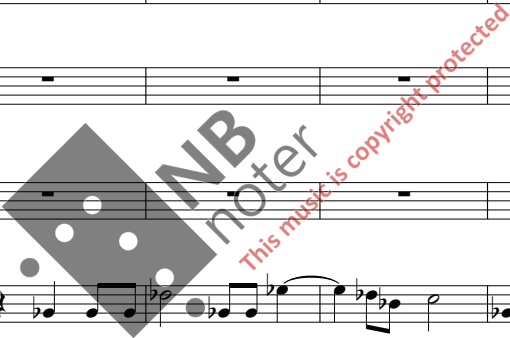

40

Fl.

Cl.

*mp*

Gr.

*mf*

Tar

Synth

*p*

Accord.

Acc impr. solo

Tub. B.

A/E

Esther:

Abd.

A - bra - ham, vår stam - far.

Kul - de og u - for

Vln. A

*mp* *p*

Vln. + div

*mp*

Vln. 1

*mp* *p*

Vln. 2

*mp* *p*

Vla.

*mp*

Vc.

*mp* *p*

Cb.

*mp* *p*

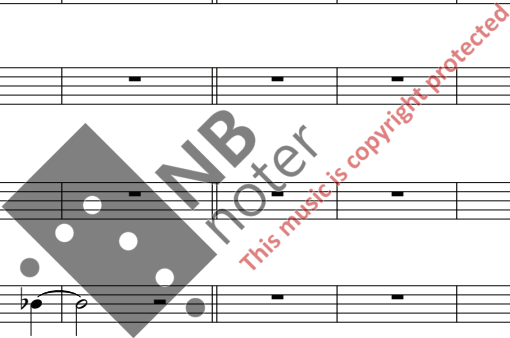

48

Fl.

Cl.

Gtr.

Tar

Synth

Accord.

Tub. B.

A/E

Abd.

Vln. A

Vln.+div

Vln. 1

Vln. 2

Vla.

Vc.

Cb.

son - lig-het. Pile - grim - en sø - ker et - ter kjær - lig het. Bry - te opp med alt jeg har

Bry - te opp med alt jeg har

*mf* (+ tre fra kor)

*p*

*ppp*

*mf*

*mf*

*mf*

*mf*

*mf*

*mf*

*mf*

*mf*

*mf*

*mf*

*mf*



53

Fl.

Cl.

Gtr.

Tar

Synth

Accord.

Tub. B.

AE

Abd.   
 som den sto - re A - bra-ham, vår stam - far.

Vln. A

Vln.+div

Vln. 1

Vln. 2

Vla.

Vc.

Cb.



*mf*

58

Fl. 

Cl. 

Gtr. 

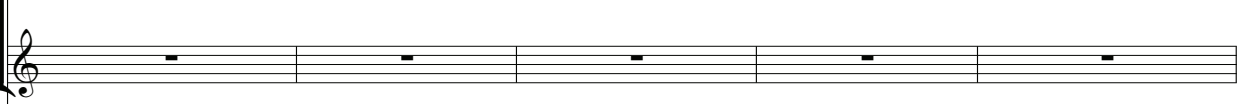
Tar. 

Synth 

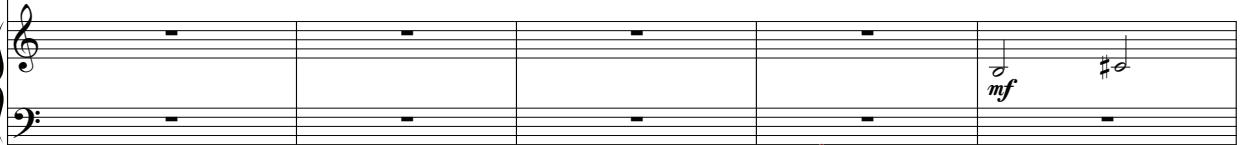
Accord. 

Tub. B. 

AE 

Abd. 

Vln. A 

Vln. +div 

Vln. 1 

Vln. 2 

Vla. 

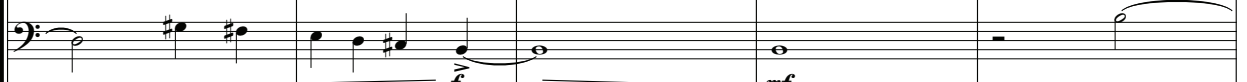
Vc. 

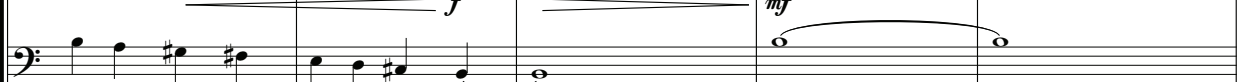
Cb. 

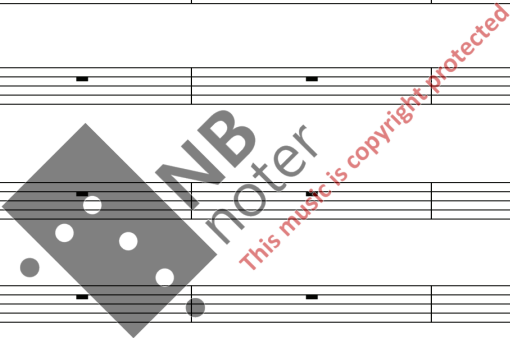

63

Fl.

Cl.

Gtr.

Tar.

Synth

Accord.

Tub. B.

A/E

Abd.

Vln. A

Vln.+div

Vln. 1

Vln. 2

Vla.

Vc.

Cb.

*p*

**NB** noter  
This music is copyright protected

# På vei til Abrahams grav del 2

Bertil Palmar Johansen  
Terje Nordby

♩ = 128

The musical score is arranged in a standard orchestral format with the following instruments and parts:

- Flute**: Treble clef, 4/4 time, rests throughout.
- Clarinet in B $\flat$** : Treble clef, 4/4 time, rests throughout.
- Guitar**: Treble clef, 4/4 time, starts in the third measure with a *mf* dynamic.
- Tar**: Treble clef, 4/4 time, rests throughout.
- Synth/samp.**: Treble and Bass clefs, 4/4 time, rests throughout.
- Accordion**: Treble and Bass clefs, 4/4 time, rests throughout.
- Cabasa**: Percussion clef, 4/4 time, starts in the first measure with a *mf* dynamic.
- Handclap** (two staves): Percussion clef, 4/4 time, starts in the first measure with a *mf* dynamic.
- Tabla**: Treble clef, 4/4 time, starts in the first measure with a *mf* dynamic.
- A+E+Kor**: Treble clef, 4/4 time, rests throughout.
- Abdullah**: Treble clef, 4/4 time, rests throughout.
- Violin A**: Treble clef, 4/4 time, starts in the third measure with a *mf* *pizz* dynamic.
- Viol.+div**: Treble clef, 4/4 time, starts in the third measure with a *mf* *pizz* dynamic.
- Violin 1**: Treble clef, 4/4 time, starts in the third measure with a *mf* *pizz* dynamic.
- Violin 2**: Treble clef, 4/4 time, starts in the third measure with a *mf* *pizz* dynamic.
- Viola**: Bass clef, 4/4 time, starts in the third measure with a *mf* *pizz* dynamic.
- Violoncello**: Bass clef, 4/4 time, starts in the third measure with a *mf* dynamic.
- Contrabass**: Bass clef, 4/4 time, starts in the third measure with a *mf* dynamic.

A large watermark is present across the center of the page, reading "NB Notel" and "This music is copyright protected".





Fl.

Cl.

Gtr.

tar

synth/sam

Accord.

Cab.

H.C.

H.C.

Tabla

A+E+kor

Abd.

Vln. A

Vln.+div

Vln. 1

Vln. 2

Vla.

Vc.

Cb.



Fl.

Cl.

Gtr.

tar

synth/sam

Accord.

Cab.

H.C.

H.C.

Tabla

A+E+kor 

pile-grim - en gå, det er iki - ke tid for å tvi - le nå.

Abd.

Vln. A

Vln.+div

Vln. 1

Vln. 2

Vla.

Vc.

Cb.

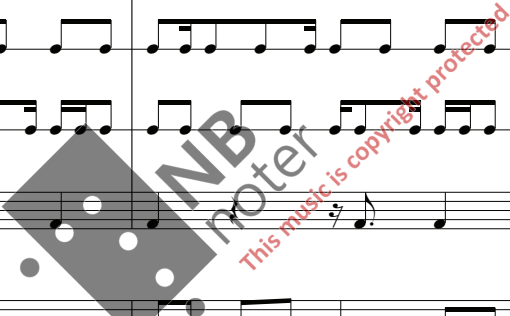

Fl. *f*

Cl. *f*

Gtr. *f*

tar *f*

synth/sam *f*

Accord. *f*

Cab. *f*

H.C. *f*

H.C. *f*

Tabla *f*

A+E+kor

Abd.

Vln. A

Vln.+div

Vln. 1 *f*

Vln. 2

Vla.

Vc.

Cb.

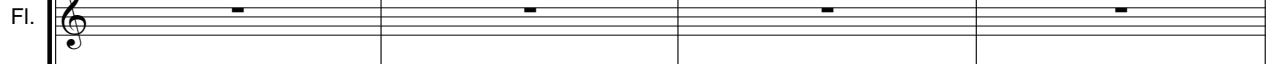

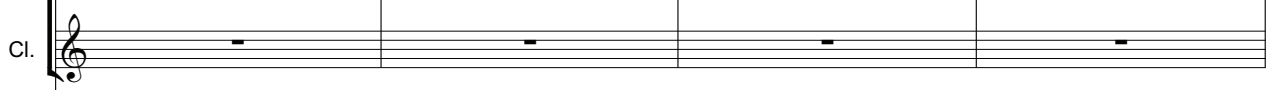
Fl. 

Cl. 

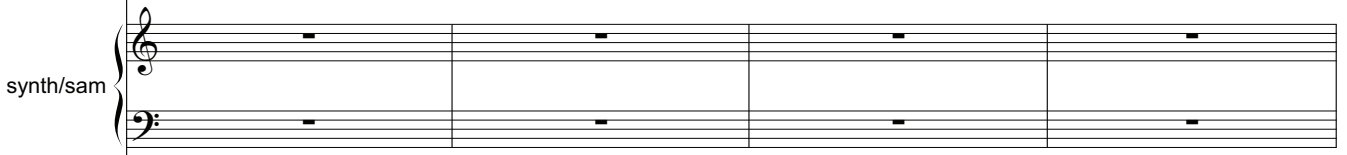
Gtr.   
tar 

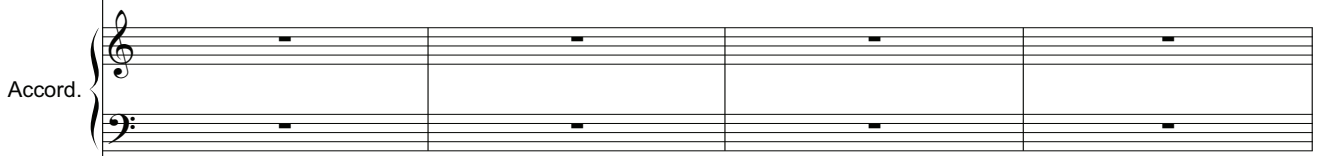
synth/sam 

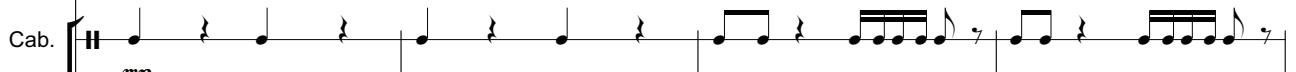
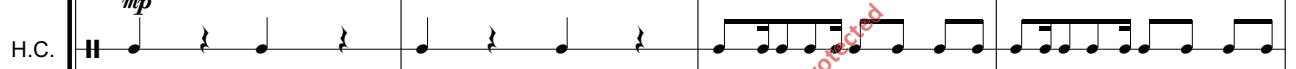
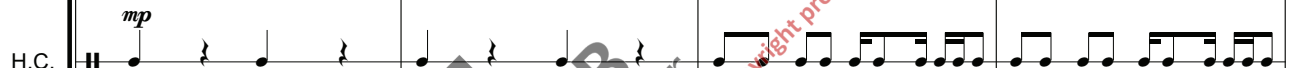
Accord. 

Cab.   
H.C.   
H.C.   
Tabla 

A+E+kor 

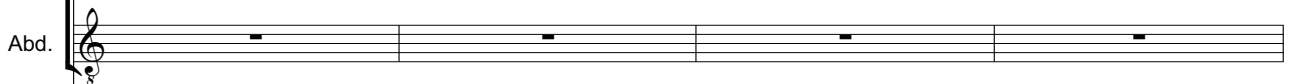
Abd. 

Vln. A   
Vln.+div   
Vln. 1   
Vln. 2   
Vla.   
Vc.   
Cb. 



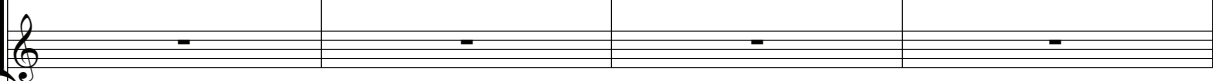

Fl. 

Cl. 

Gtr. 

tar 

synth/sam 

Accord. 

Cab. 

H.C. 

H.C. 

Tabla 

A+E+kor   
 Fri oss i-fra his - to - ri - ens garn, la stjer-ne - ne ly - se på A-bra - hams barn.

Abd. 

Vln. A 

Vln.+div 

Vln. 1 

Vln. 2 

Vla. 

Vc. 

Cb. 



Fl. *mp*

Cl. *mp*

Gtr.

tar

synth/sam *mp*

Accord. *mp*

Cab.

H.C.

H.C.

Tabla

A+E+kor

Anna+Esther

Krang-el og kiv, et fråd-en - de hav. Vi er på vei til

Abd.

Vln. A

Vln.+div

Vln. 1 *mp* arco

Vln. 2 *mp* arco

Vla. *mp* arco

Vc. *mp* arco

Cb. *mp* arco



Fl.

Cl.

Gtr.

tar

synth/sam

Accord.

Cab.

H.C.

H.C.

Tabla

A+E+kor

Abd.

Vln. A

Vln.+div

Vln. 1

Vln. 2

Vla.

Vc.

Cb.

Fl. *[Musical notation]*

Cl. *[Musical notation]*

Gtr. *[Musical notation]*

tar *[Musical notation]*

synth/sam *[Musical notation]*

Accord. *[Musical notation]*

Cab. *[Musical notation]*

H.C. *[Musical notation]*

H.C. *[Musical notation]*

Tabla *[Musical notation]*

A+E+kor  
A - bra - hams grav, i ens - om - het skal pil-grim - en gå,

Abd. *[Musical notation]*

Vln. A *[Musical notation]*

Vln.+div *[Musical notation]*

Vln. 1 *[Musical notation]*

Vln. 2 *[Musical notation]*

Vla. *[Musical notation]*

Vc. *[Musical notation]*

Cb. *[Musical notation]*



Fl. *f*

Cl. *f*

*mp*

Gtr.

tar

synth/sam

Accord.

Cab. *susp cym.*

H.C. *mf* Triangle

H.C. *mf* Glockenspiel

Tabla *mp* Crotales

*mp*

A+E+kor

tid-en er in - ne, nå skal vi gå.

Abd. (Rumis bønn)

♩ = 76 Kom, kom, u-an-sett hvem du er. en

Vln. A

Vln.+div

Vln. 1 *f*

Vln. 2 *f*

Vla. *f*

Vc. *f*

Cb. *f*

Fl.

Cl.

Gtr.

tar

synth/sam

Accord.

susp.sym

Tri.

Glock.

Crot.

A+E+kor

Abd.

Vln. A

Vln.+div

Vln. 1

Vln. 2

Vla.

Vc.

Cb.

*mp*

*mf*

*arco*

*mp*

*mp*

*mp*

*mp*

guds-dyrk-er, el-ler en søk - er. Det spil-ler ing-en rol - le. Er du en rast-løs elsk - er av opp- brudd.

*This music is copyright protected*

Fl.

Cl.

Gtr.

tar

synth/sam

Accord. *mf*

susp.sym

Tri.

Glock.

Crot.

A+E+kor

Abd.   
 Det-te er ik ke for-tvil-els-ens ka-ra - va - ne Kom, kom, u an-sett hvem du er. Selv om du har brutt di-ne løf-ter tus -

Vln. A

Vln.+div

Vln. 1

Vln. 2

Vla.

Vc.

Cb.

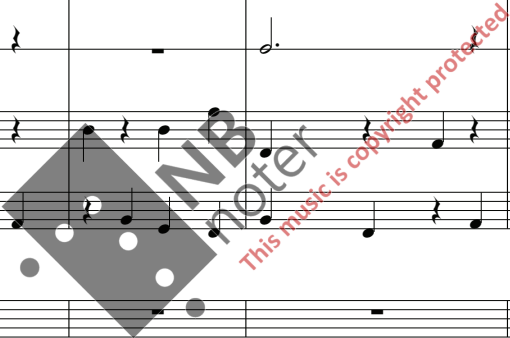



Fl.   
 Cl.

Gtr.   
 tar

synth/sam   
*mf*   
*f*   
 sekkepipe   
*f*

Accord.   
*f*

Cab.   
 H.C.   
 H.C.   
 Tabla

A+E+kor

Abd.

Vln. A   
 Vln.+div   
*f*   
 arco   
*f* dramatisk - gresk vokal-impro

Vln. 1

Vln. 2

Vla.

Vc.   
*f*   
 pizz   
 pizz

Cb.   
*f*

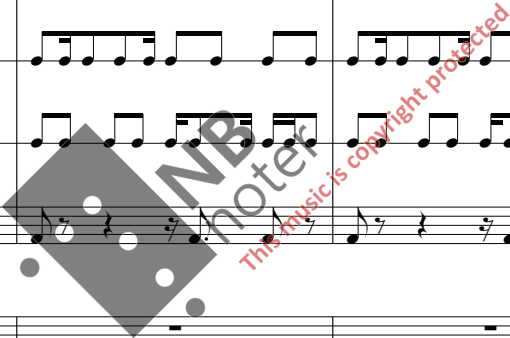

Fl.

Cl.

Gtr.

tar

synth/sam

Accord.

Cab.

H.C.

H.C.

Tabla

A+E+kor

Abd.

Vln. A

Vln.+div

Vln. 1

Vln. 2

Vla.

Vc.

Cb.

*NB noter*  
*This music is copyright protected*

*f*

*arco*

*f*

*arco*

*f*

kromhorn ev. 8va basso

60

27

Fl.

Cl.

Gtr.

tar

synth/sam

Accord.

Cab.

H.C.

H.C.

Tabla

A+E+kor

Abd.

Vln. A

Vln.+div

Vln. 1

Vln. 2

Vla.

Vc.

Cb.

*f*

*arco*

*pizz*

*pizz*

Fl.

Cl.

Gtr.

tar

synth/sam

Accord.

Cab.

H.C.

H.C.

Tabla

A+E+kor

Abd.

Vln. A

Vln.+div

Vln. 1

Vln. 2

Vla.

Vc.

Cb.

**NB**  
noter  
This music is copyright protected



Fl.

Cl.

Gtr.

tar

synth/sam

Accord.

Cab.

H.C.

H.C.

Tabla

A+E+kor

Abd.

Vln. A

Vln.+div

Vln. 1

Vln. 2

Vla.

Vc.

Cb.

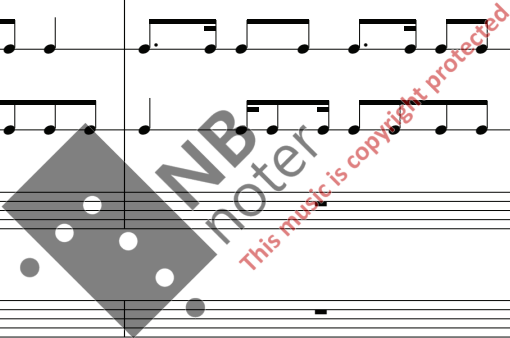

# Hvem tenner alle himmelens lys del 3

Bertil Palmar Johansen  
Terje Nordby

Flute  $\text{♩} = 76$

Clarinet in B $\flat$  *mf*

Guitar *mf*

Tar

Synth *mf*

Accordion *mp*

Temple Blocks

Tom-toms

Marimba

Esther/Anna  $\text{♩} = 76$

Abdullah

Violin A *mf*

Viol.+div *mf*

Violin 1 *mf*

Violin 2 *mf*

Viola *mf*

Cello/CB *mf*

The musical score is arranged in a system of staves. The top section includes Flute, Clarinet in B $\flat$ , Guitar, Tar, Synth, and Accordion. The middle section includes Temple Blocks, Tom-toms, and Marimba. The bottom section includes vocal parts for Esther/Anna and Abdullah, and string parts for Violin A, Violin 1, Violin 2, Viola, and Cello/CB. The tempo is marked as  $\text{♩} = 76$ . Dynamics include *mf* and *mp*. A watermark for 'NB noter' is visible across the middle of the page.



11

Fl.

Cl. *mp*

Gtr. *mp*

Tar.

Sy/sam.

Accord. *mp*

T. Bl.

Tom-t.

Mar.

Esther;

E/A  
Se den førs - te stjern - en høyt ov - er - vårt telt, Eu - frats bred - der mørkn - er.

Abd.

Vln. A *mp* pizz

Vln+div *mp*

Vln. 1 *mp*

Vln. 2 *mp*

Vla. *mp*

Vc./cb *mp*



22

Fl.

Cl.

Gr.

Tar.

Sy/sam.

Accord.

T. Bl.

Tom-t.

Mar.

E/A

Abd.

Vln. A

Vln+div

Vln. 1

Vln. 2

Vla.

Vc./cb

To Hp.

This music is copyright protected

25

Fl.

Cl. *mp*

Gtr. *mf*

Tar.

Harp *mf*

Hp.

Accord.

T. Bl.

Tom-t.

Mar.

resitasjon  
 Anna; Det må finnes en Gud  
 langt der oppe mellom stjernene, sa barnet Abraham

De døde steinstøttene folk tilber,  
 kan da ikke være hellige?  
 Det må finnes noe mer.

Faren svarte: Folk må få tro  
 det de tror.  
 Det er undringens lys som skinner på himmelen.

E/A

Abd.

Vln. A *arco*

Vln+div *p arco*

Vln. 1 *p arco*

Vln. 2 *mf arco*

Vla. *p arco*

Vc./cb *p*



31

Fl.

Cl.

Gtr.

Tar.

Hp.

Accord.

T. Bl.

Tom-t.

Mar.

Mange år senere døde faren. Da var det som om Gud  
 Den natten så Abraham på stjernene igjen. snakket til han.

E/A

Abd.

Vln. A

Vln+div

Vln. 1

Vln. 2

Vla.

Vc./cb

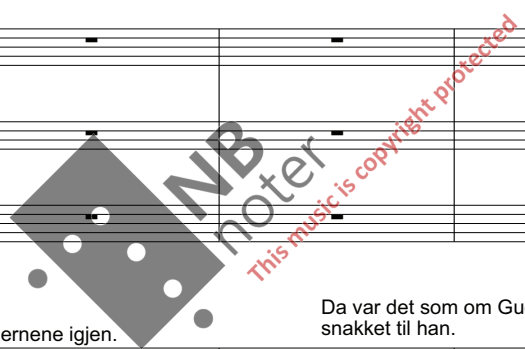



36

Fl.

Cl.

Gtr.

Tar.

Sy/sam.

Accord.

T. Bl.

Tom-t.

Mar.

E/A

Abd.

alt du har, dra bort fra det-te land - et, Frem-med al - le ste - der,

Vln. A

Vln+div

Vln. 1

Vln. 2

Vla.

Vc./cb

41

Fl.

Cl.

Gtr.

Tar

Sy/sam.

Accord.

T. Bl.

Tom-t.

Mar.

E/A

Abd.

Husk din et - ter - slett bli stor som him - mel-ens lys.

Vln. A

Vln+div

Vln. 1

Vln. 2

Vla.

Vc./cb

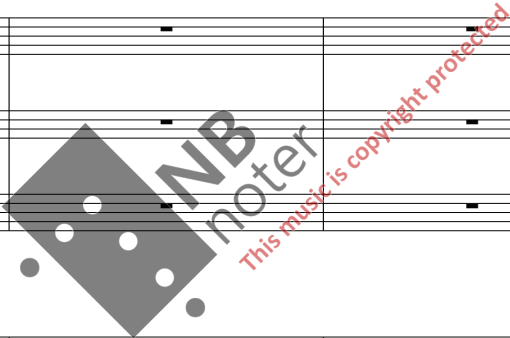

# Ild over byen min del 4

39

Bertil Palmar Johansen  
Terje Nordby

$\text{♩} = 104$

The musical score is arranged in a standard orchestral format with the following parts from top to bottom:

- Flute
- Clarinet in B $\flat$
- Guitar
- Tar
- Synth marimba
- Accordion
- Handclap
- Xylophone
- Marimba
- Anna/Esther Kor
- Abdullah
- Violin A
- Viol. + div
- Violin 1
- Violin 2
- Viola
- Violoncello
- Contrabass

The score is in 4/4 time and features a tempo of 104 beats per minute. The dynamic marking *mf* (mezzo-forte) is used throughout. The string section (Violin A, Viol. + div, Violin 1, Violin 2, Viola, Violoncello, and Contrabass) is marked *pizz* (pizzicato). A large watermark reading "NBwater" and "This music is copyright protected" is overlaid on the score.

4

Fl.  
Cl.  
Gtr.  
tar  
synth  
Accord.  
H.C.  
Xyl.  
Mar.  
A/E/K  
Abd.  
Vln. A  
Vln.+div  
Vln. 1  
Vln. 2  
Vla.  
Vc.  
Cb.

This music is copyright protected

7 kromhorn 41

Fl.

Cl. *f*

Gtr.

tar

synth

Accord.

H.C.

Xyl.

Mar.

A/E/K

Abd.

Vln. A *arco* *f*

Vln.+div *mf*

Vln. 1

Vln. 2

Vla.

Vc.

Cb.

Fl.

Cl.

Gtr.

tar

synth

Accord.

H.C.

Xyl.

Mar.

A/E/K

Abd.

Vln. A

Vln.+div

Vln. 1

Vln. 2

Vla.

Vc.

Cb.

NB noter

This music is copyright protected

Fl.

Cl.

Gr. *mf*

tar

synth *p*

Accord.

H.C.

Xyl.

Mar. *mp*

A/E/K

Abd.

Vln. A *mp*

Vln.+div *mp*

Vln. 1 *mp*

Vln. 2 *mp*

Vla. *mp*

Vc. *mf*

Cb. *mf*



Fl.

Cl.

Gtr.

tar

synth

Accord.

H.C.

Xyl.

Mar.

A/E/K

Abd.

Vln. A

Vln.+div

Vln. 1

Vln. 2

Vla.

Vc.

Cb.

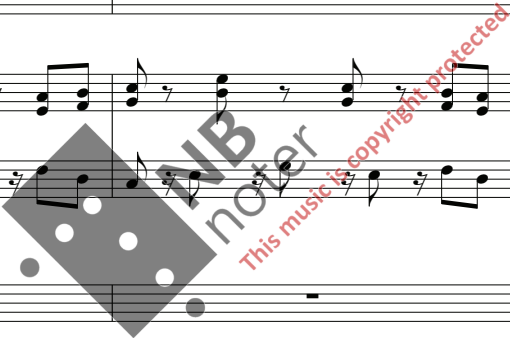



Fl.

Cl.

Gtr.

tar

synth

Accord.

H.C.

Xyl.

Mar.

A/E/K

Abd.

Vln. A

Vln.+div

Vln. 1

Vln. 2

Vla.

Vc.

Cb.



Fl.

Cl.

Gtr.

tar

synth

Accord.

H.C.

Xyl.

Mar.

A/E/K

Esther:  
Kamp-en mot ter - ro star - ter nå,

Abd.

Abdullah:  
Hver og en som dør må vi hus - ke.

Vln. A

Vln.+div

Vln. 1

Vln. 2

Vla.

Vc.

Cb.

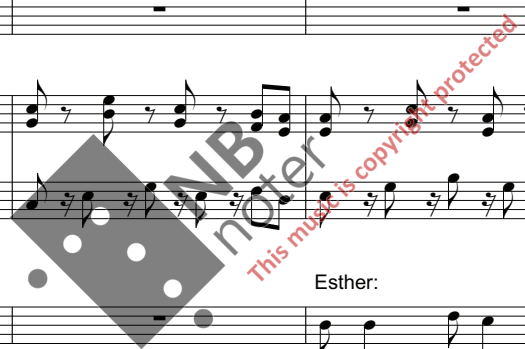

Fl. *mf*

Cl. *mf*

Gtr. tar

synth *mf*

Accord. *mf*

H.C.

Xyl.

Mar. *mf*

A/E/K *solister + kor kor*  
Skal bom-be mø - te bom-be? Tann for tann, Skal ter-ror mø - te ter - ror? Tann for tann,

Abd.  
Skal bom-be mø - te bom-be? Tann for tann, Skal ter-ror mø - te ter - ror? Tann for tann,

Vln. A *f*

Vln.+div *f*

Vln. 1 *f*

Vln. 2 *f*

Vla. *f*

Vc. *f*

Cb. *f*



Fl. *mf*

Cl. *mf*

Gtr. tar

fløyte-bambus *mf*

synth

Accord. *mf*

H.C. *mf*

Xyl. *mf*

Mar.

A/E/K

Abd.

Vln. A arco *mf*

Vln.+div *mf*

Vln. 1 *mf*

Vln. 2 *mf*

Vla. *mf*

Vc. *mf*

Cb. *mf*

Esther: Anna/Esther+kor

Abdullah A - bra ham ser du oss? A - bra-ham vi\_

A - bra ham, hvor er du? A - bra ham, vi\_

+kor

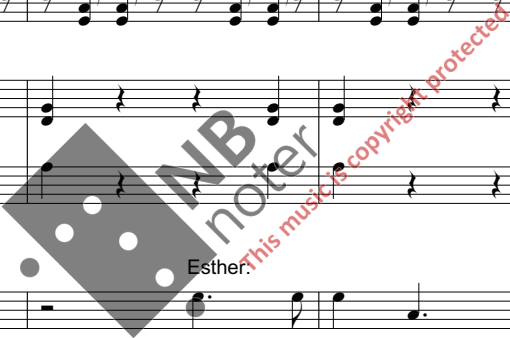

Fl. *f*

Cl. *f*

Gtr. *f*

tar *f*

synth *f*

Accord. *f*

H.C. *f*

Xyl. *f*

Mar. *f*

A/E/K  
let - er et - ter deg.

Abd.  
let - er et - ter deg.

Vln. A *f*

Vln.+div *f*

Vln. 1 *f* arco

Vln. 2 *f* arco

Vla. *f* arco

Vc. *f* arco

Cb. *f*

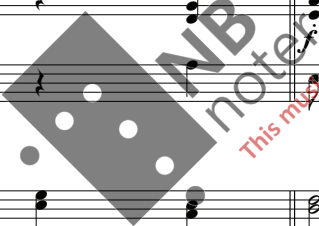

This music is copyright protected

Fl.

Cl.

Gr.

tar

synth

Accord.

H.C.

Xyl.

Mar.

A/E/K

Abd.

Vln. A

Vln.+div

Vln. 1

Vln. 2

Vla.

Vc.

Cb.

A - - bra - ham hvor er du!

A - - bra - ham hvor er du!

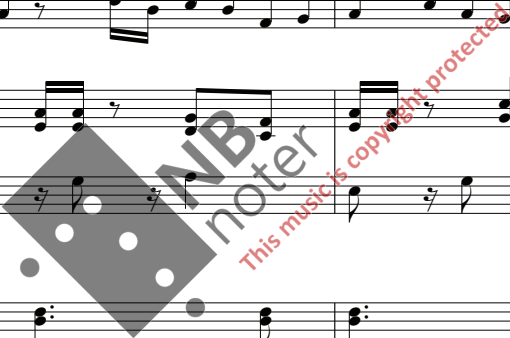

# Jerusalem del 5

51

Bertil Palmar Johansen  
Terje Nordby

$\text{♩} = 92$

Flute

Clarinet in B $\flat$

Guitar

Tar

Harp

Synth *mp*

Accordion

Shekere *ad lib. (puls)*  
*mf* *ad lib. (puls)*

Cabasa *mf* *ad lib. (puls)*

Egg Shaker *mf* *ad lib. (puls)*

Marimba *f* *mf*

Esther/Anna kor  
Vi kom fra hvert vårt

Abdullah

Violin A *p*

Viol+div *p*

Violin 1 *p*

Violin 2 *p*

Viola *p* *pp*

Cello/CB *p*

Fl. *mf*<sup>3</sup>

Cl.

Gtr. *mf*<sup>3</sup>

tar

Hp.

Accord.

Shek.

Cab.

E.S.

Mar. *mf*<sup>3</sup>

E/A/K  
hus, Til mar - ke - ne i sol og

Abd.

Vln. A *p*

Vln+div *mf* pizz <sup>3</sup> arco *p*

Vln. 1 *p*

Vln. 2 *mf* pizz <sup>3</sup> arco *p*

Vla. *p*

Vc./cb *p*

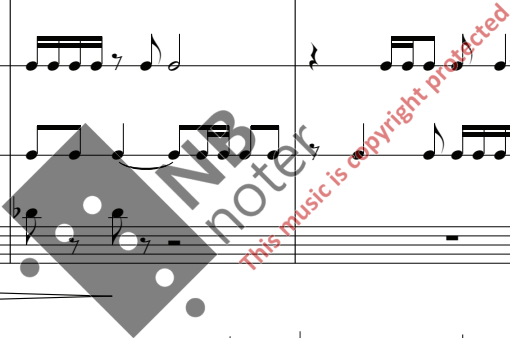



Fl.

Cl.

Gtr.

tar

Hp.

Accord.

Shek.

Cab.

E.S.

Mar.

E/A/K

Abd.

Vln. A

Vln+div

Vln. 1

Vln. 2

Vla.

Vc./cb

Fl. *mf* <sup>3</sup>

Cl. *mf* <sup>3</sup>

Gtr. *mf* <sup>3</sup>

tar *mf* <sup>3</sup>

Hp.

Accord.

Shek.

Cab.

E.S.

Mar. <sup>3</sup>

E/A/K  
regn, Av tå - re - ne om nat - ten

Abd.

Vln. A

Vln+div *mf* <sup>3</sup> pizz

Vln. 1 *mf* <sup>3</sup> pizz

Vln. 2 *mf* <sup>3</sup> arco

Vla.

Vc./cb



Fl. *p* <sup>3</sup> *mp*

Cl.

Gtr. *p*

tar

Hp. *To Pno. Piano* *mf*

Accord.

Shek.

Cab.

E.S.

Mar. *mf*

E/A/K ble vi født, for - lot alt vi ei - de,

Abd. Da-vid sam-ler et

Vln. A *pizz* *mf* arco

Vln+div *mf*

Vln. 1 *pizz* *mf* arco

Vln. 2 *mf*

Vla. *mf* cello

Vc./cb *mf*

Fl.

Cl.

*pp*

Gtr.

tar

Pno.

Accord.

Shek.

Cab.

E.S.

Mar.

E/A/K

Abd.

hel - lig ri - ke, Je-sus sto opp fra de dø - de, Gud tok sin pro - fet fra Mek-ka,

Vln. A

Vln+div

Vln. 1

Vln. 2

Vla.

Vc./cb

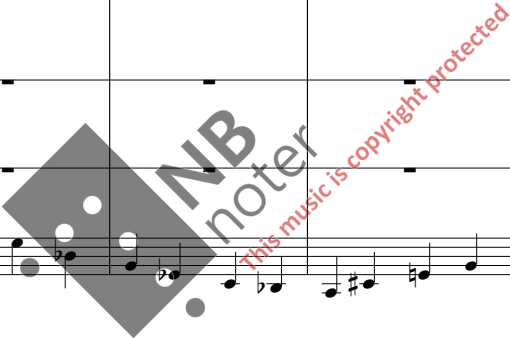





Fl. 

Cl. 

Gtr. 

tar 

Hp. 

Accord. 

Shek. 

Cab. 

E.S. 

Mar. 

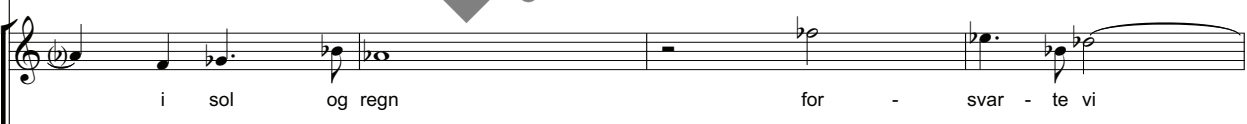
E/A/K 

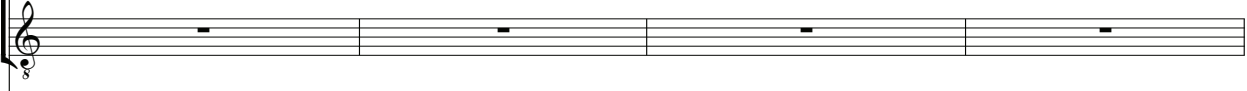
Abd. 

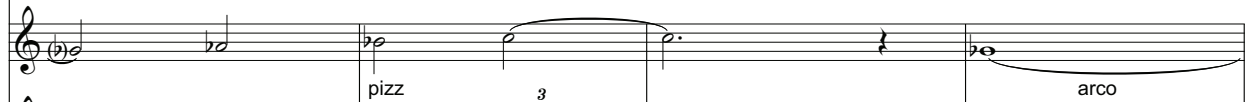
Vln. A 

Vln+div 

Vln. 1 

Vln. 2 

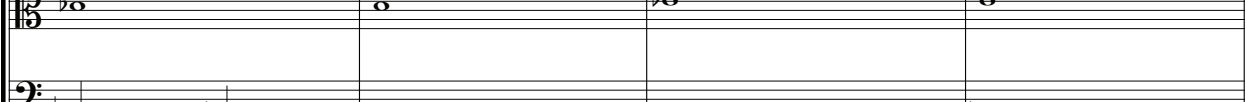
Vla. 

Vc./cb 



Fl.

Cl.

Gtr.

tar

Hp.

Accord.

Shek.

Cab.

E.S.

Mar.

E/A/K

Abd.

Vln. A

Vln+div

Vln. 1

Vln. 2

Vla.

Vc./cb

Fl. and Cl. staves with musical notation. Flute part includes a triplet of eighth notes marked *mf* 3.

Guitar and Tambourine staves with musical notation. Guitar part includes a triplet of eighth notes marked *mf* 3.

Piano (Hp.) staff with musical notation.

Accordion (Accord.) staff with musical notation.

Shekere (Shek.), Cabasa (Cab.), Electric Shaker (E.S.), and Maracas (Mar.) staves with musical notation. Maracas part includes a triplet of eighth notes marked 3.

E/A/K staff with lyrics: "vår gud med hvert vårt sverd, En".

Abd. staff with musical notation.

Vln. A staff with musical notation.

Vln+div staff with musical notation. Violin part includes a triplet of eighth notes marked *mf* pizz 3.

Vln. 1 staff with musical notation.

Vln. 2 staff with musical notation. Violin part includes a triplet of eighth notes marked *mf* pizz 3.

Vla. staff with musical notation.

Vc./cb staff with musical notation.

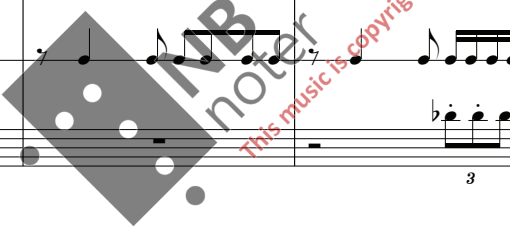

60 42

Fl. *f*

Cl. *mp*

Gtr. *mf*

tar

Hp. *To Pno. Piano mp*

Accord. *mf*

Shek.

Cab.

E.S.

Mar. *mp*

E/A/K  
tid er for - bi. Du skal smi di - ne sverd om til en plog. Smi spy-de - ne om til en

Abd.

Vln. A *pizz mf*

Vln+div *pizz mf*

Vln. 1 *arco mf*

Vln. 2 *pizz mf*

Vla. *pizz mf*

Vc./cb *f*

Esther:

*This music is copyright protected*

**NB noter**



Fl. *mf*

Cl. *mf*

Gtr.

tar

Pno. *mf*

Accord. *mf*

Shek.

Cab.

E.S.

Mar. *pp*

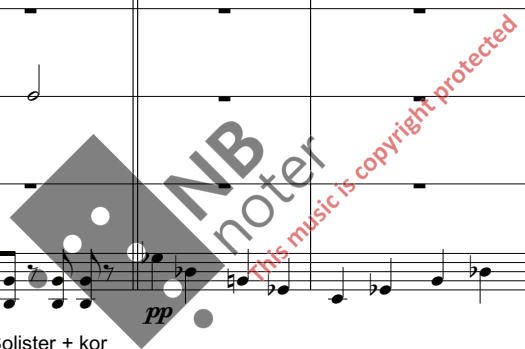

E/A/K Solister + kor  
vin-gårds - kniv, for A - bra - ham. Dav - ids ri - ke, Je - ru - sa - lem,

Abd. +kor  
for A - bra - ham. Dav - ids ri - ke, Je - ru - sa - lem,

Vln. A *mf*

Vln+div *mf* arco

Vln. 1 *mf* arco

Vln. 2 *mf* arco

Vla. *mf*

Vc./cb *mf*

Fl.

Cl.

Gtr.

tar

Pno.

Accord.

Shek.

Cab.

E.S.

Mar.

E/A/K

Abd.

Vln. A

Vln+div

Vln. 1

Vln. 2

Vla.

Vc./cb

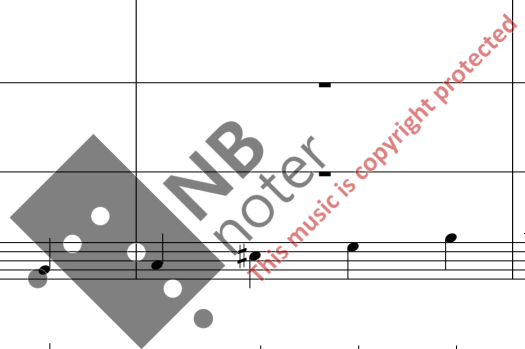

Fl.

Cl.

Gtr.

tar

Pno.

Accord.

Shek.

Cab.

E.S.

Mar.

E/A/K   
fet fra Mek - ka, Je - ru - sa - lem.

Abd.   
fet fra Mek - ka, Je - ru - sa - lem.

Vln. A

Vln+div

Vln. 1

Vln. 2

Vla.

Vc./cb

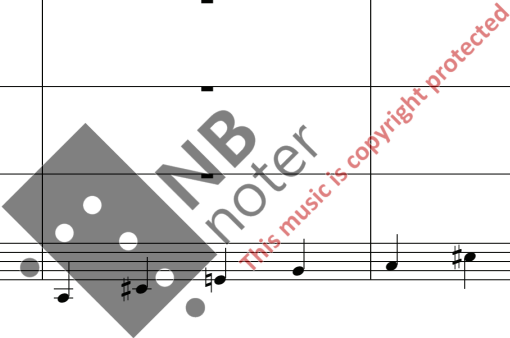

# Drømmene i oss del 6

Bertil Palmar Johansen

$\text{♩} = 320$

Flute

Clarinet in B $\flat$   
*mf*

Guitar  
*mf*

Tar

Synth  
sekkepipe  
*mf*

Accordion  
*mf*

Triangle

Cymbals  
Tambourine  
*mf*

Tom-toms

Handclap  
*mf*

Handclap  
*mf*

Wood Block  
*mf*

Abrahams sendebud - dans

Anna

Violin A

Viol+div

Violin 1  
pizz  
*mf*

Violin 2  
pizz  
*mf* pizz

Viola  
*mf* pizz

Violoncello  
*mf* pizz

Contrabass  
*mf* pizz

7 65

Fl.

Cl.

Gtr.

tar

Synth

Accord.

Tri.

Tamb.

Tom-t.

H.C.

H.C.

W.B.

Anna

Vln. A

Vln+div

Vln. 1

Vln. 2

Vla.

Vc.

Cb.

*mf*

*mf*

*mf*

MB Notes

This music is copyright protected

This page contains a musical score for various instruments. The instruments listed on the left are: Fl. (Flute), Cl. (Clarinet), Gtr. (Guitar), tar. (Tambourine), Synth (Synthesizer), Accord. (Accordion), Tri. (Triangle), Tamb. (Tambourine), Tom-t. (Tom-tom), H.C. (Hi-Cymbal), W.B. (Woodblock), Anna (Vocal line), Vln. A (Violin A), Vln+div (Violin + Diva), Vln. 1 (Violin 1), Vln. 2 (Violin 2), Vla. (Viola), Vc. (Violoncello), and Cb. (Contrabasso). The score is in 4/4 time and features a key signature of two flats. The music is primarily in a minor mode. The score is marked with a dynamic of *f* (forte) in several places. A large watermark 'NB noter' is present across the center of the page, along with the text 'This music is copyright protected'. The page number '66' is in the top left corner, and the rehearsal mark '13' is at the top of the first staff.

Fl. *mf*

Cl. *mf*

Gtr. *mf*

tar

Synth *mf*

Accord. *mf*

Tri.

Cym.

Tom-t.

H.C. *mf*

H.C. *mf*

W.B. *mf*

Anna *mf* impro. osv impro.  
 ha la la vei - o ha la la vei - o ha la la vei - o

Vln. A

Vln+div

Vln. 1 *mf*

Vln. 2 *mf*

Vla. *mf*

Vc. *mf*

Cb. *mf*

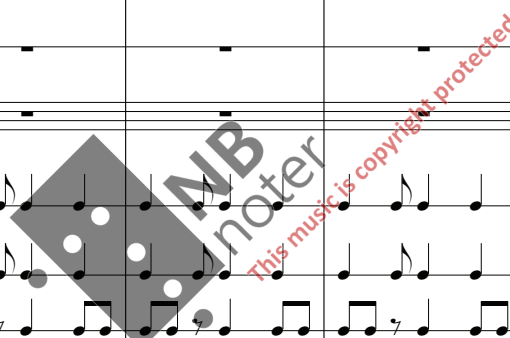





Fl.

Cl.

Gtr.

tar

Synth

Accord.

Tri.

Cym.

Tom-t.

H.C.

H.C.

W.B.

Anna   
 Kom og se, det som skjer det an-går deg og søk - et star - ter nå. Jeg er din venn, vi har en drøm, sam-men skal

Vln. A

Vln+div

Vln. 1

Vln. 2

Vla.

Vc.

Cb.

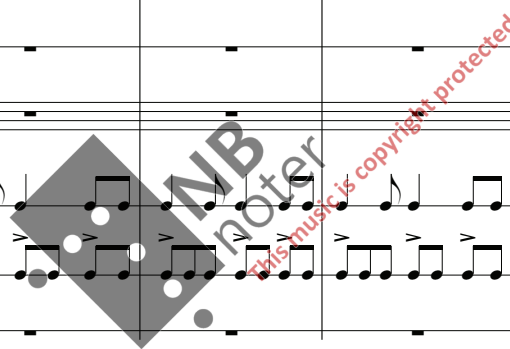

Fl.

Cl.

Gtr.

tar

Synth

Accord.

Tri.

Cym.

Tom-t.

H.C.

H.C.

W.B.

Anna   
 vi gå sti - e - ne frem og vi skal pluk - ke bloms - te - ne langs vår pil - grims - led. Drøm - me - ne i oss, ja det er de

Vln. A

Vln+div

Vln. 1

Vln. 2

Vla.

Vc.

Cb.

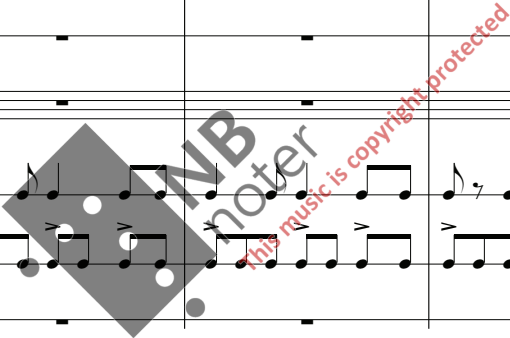

Fl. *mf*

Cl. *mf*

Gtr. *mf*

tar

Synth *mf*

Accord. *mf*

Tri.

Cym.

Tom-t.

H.C.

H.C.

W.B.

Anna *impro.* *osv*  
 vi skal fin-ne. ha la la vei - o ha la la vei - o

Vln. A *mf*

Vln+div *mf*

Vln. 1 *mf*

Vln. 2 *mf*

Vla. *mf*

Vc. *mf*

Cb. *mf*

*NB noter*  
*this music is copyright protected*

Fl. *mf*

Cl.

Gtr.

tar

Synth

Accord.

Tri. *mf*

Cym. *mf*

Tom-t. *mf*

H.C. *mf*

H.C.

W.B. *mf*

Anna rrrrrr..... med gliss (Abrahams dans)

Vln. A arco sul.pont. *mf*

Vln+div arco *mf* sul.pont.

Vln. 1 *mf*

Vln. 2

Vla.

Vc. *mf*

Cb. *mf*

Bagp. 

Cl. 

Gtr. 

tar 

Synth 

Accord. 

Tri. 

Cym. 

Tom-t. 

H.C. 

H.C. 

W.B. 

Anna 

Vln. A 

Vln+div 

Vln. 1 

Vln. 2 

Vla. 

Vc. 

Cb. 

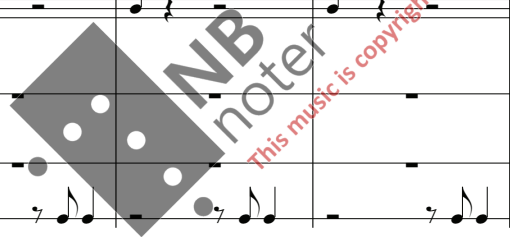

Bagp.

Cl.

Gtr.

tar

Synth

Accord.

Tri.

Cym.

Tom-t.

H.C.

H.C.

W.B.

Anna

Vln. A

Vln+div

Vln. 1

Vln. 2

Vla.

Vc.

Cb.

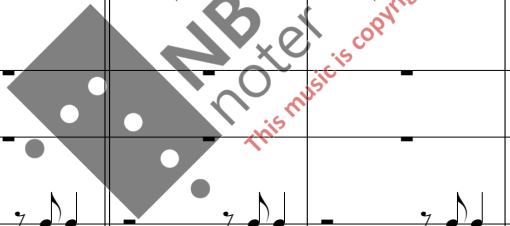

Bagp. 

Cl. 

Gtr. 

tar 

Synth 

Accord. 

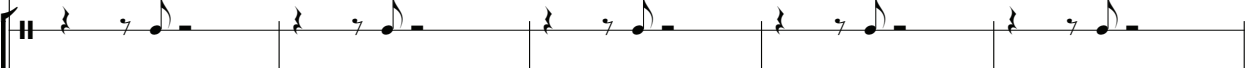
Tri. 

Cym. 

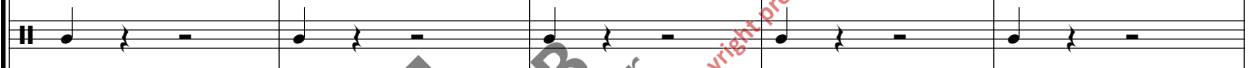
Tom-t. 

H.C. 

H.C. 

W.B. 

Anna 

Vln. A 

Vln+div 

Vln. 1 

Vln. 2 

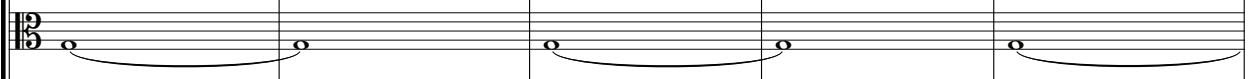
Vla. 

Vc. 

Cb. 

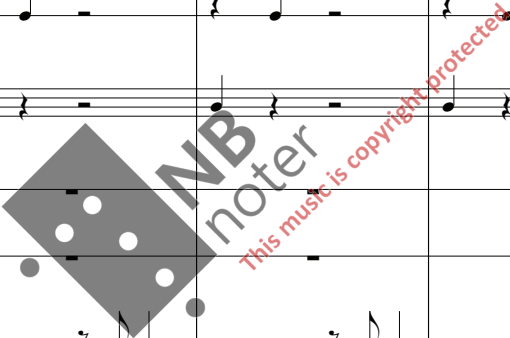

76

71

Musical score for measures 76-80. The score includes parts for Bagp., Cl., Gtr., tar, Synth, Accord., Tri., Cym., Tom-t., H.C., W.B., Anna, Vln. A, Vln+div, Vln. 1, Vln. 2, Vla., Vc., and Cb. The woodwind and string parts feature melodic lines, while the percussion parts include cymbals, tom-toms, and wood blocks. The string parts are marked with *p* (piano). A watermark for 'NB noter' is visible in the center of the page.





Fl.

Cl.

Gtr.

tar

synth

Accord.

1

2

3

Anna

Esther

Abdullah

Vln. A

Vln.+div

Vln. I

Vln. 2

Vla.

Vc.

Cb.



Fl.

Cl.

Gtr.

tar

synth

Accord.

1

2

3

Anna

Esther

Abdullah

Vln. A

Vln.+div

Vln. I

Vln. 2

Vla.

Vc.

Cb.

brutt akk

*mf*

*mp*

*mf*

*mf*

*mf*

pizz

*mf*

*mf*

ham,

Is-ak,

Is-ak

Of-fer

Of-fer

ak.

Is-ak,

ak.

Is-ak,

Hvem står i vei - en og prø-ver å hind - re vår pile - grims - ferd, og si-er



Fl. *p p p p p p*

Cl. *f f*

Gtr. *[Guitar notation]*

tar *[Tambourine notation]*

synth *[Synthesizer notation]*

Accord. *f f*

1 *f*  
Svek-et svek-et A - bra - ham, A - bra - ham.

2 *f*  
Kom Is-ak kom

3 *f*  
Kom Is-ak kom Is - ak,

Anna *[Musical notation]*

Esther *[Musical notation]*

Abdullah  
han er selv-es - te A - bra - ham

Vln. A *f f*

Vln.+div *f f*

Vln. 1 *f f*

Vln. 2 *f f*

Vla. *f arco*

Vc. *f arco*

Cb. *f*

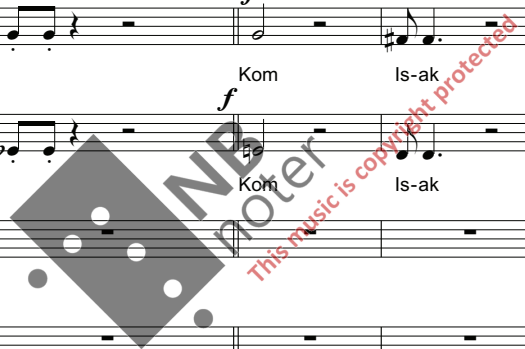

Fl. *mp*

Cl. *mp*

Gtr.

tar

synth

Accord.

1 *mf*

Is - ak full av til - lit, han tok min hånd, vi gikk langs sti - en, Jeg så han inn i øy-ne - ne og løy.

2 *mf*

*mf* Is - ak full av til - lit, han tok min hånd, vi gikk langs sti - en, Jeg så han inn i øy-ne - ne og løy.

3

Is - ak full av til - lit, han tok min hånd, vi gikk langs sti - en, Jeg så han inn i øy-ne - ne og løy.

Anna

Esther

Abdullah

Vln. A *mp*

Vln.+div *mp*

Vln. I *mp*

Vln. 2 *mp*

Vla. *mp*

Vc.

Cb.

Fl. *f* *mp*

Cl. *f* *mp*

Gtr.

tar

synth *f*

Accord. *f* *mp*

1 *f* *mf*

Ni år! Jeg skul-le skjæ - re ov - er stru - pen hans med en kniv. Mo - ri - a. ik-ke

2 *f* *mf*

Ni år! Jeg skul-le skjæ - re ov - er stru - pen hans med en kniv. Mo - - a, ik-ke

3 *f* *mf*

Ni år! Jeg skul-le skjæ - re ov - er stru - pen hans med en kniv. Mo - - a, ik-ke

Anna

Esther

Abdullah

Vln. A *f* *mp*

Vln.+div *f* *mp*

Vln. I *f* *mp*

Vln. 2 *f* *mp*

Vla. *f* *mp*

Vc. *f*

Cb. *f*



Fl.

Cl.

Gtr.

tar

synth

Accord.

1

2

3

Anna

Esther

Abdullah

Vln. A

Vln.+div

Vln. I

Vln. 2

Vla.

Vc.

Cb.

Fl.

Cl.

Gtr.

tar

synth

Accord.

1

2

3

Anna

Esther

Abdullah

Vln. A

Vln.+div

Vln. I

Vln. 2

Vla.

Vc.

Cb.

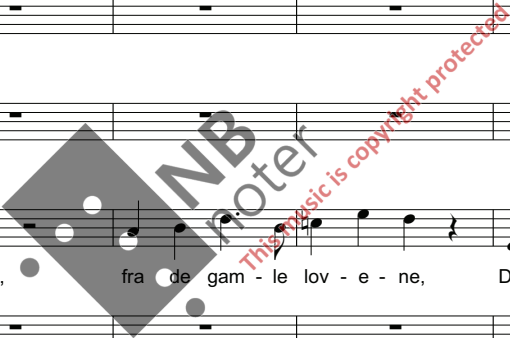



Fl. *f*

Cl. *f*

Gtr. *f*

tar

synth *f* *mp*

Accord. *f* *mp*

1 *f* *mp*

2 *f* *mp*

3 *f* *mp*

Anna *f* *mp*

Esther

Abdullah *f* *mp*

Vln. A *f* *mp*

Vln.+div *f* *mp*

Vln. I *f* *mp*

Vln. 2 *f* *mp*

Vla. *f* *mp*

Vc. *f* *mp* pizz

Cb. *f* *mf*

Mo - ri - a. Vår-en, sne-en,  
 Mo - ri - a. Vår-en, sne-en,  
 Mo - ri - a. Vår-en, sne-en,

høy - re - eks-tre-mist i for-klød - ning,

Vi tol-ker teks ten,



Fl.

Cl.

Gtr.

tar

synth

Accord.

1 sol-en, regn-et, ild-en, frost-en, håp-et,

2 sol-en, regn-et, ild-en, frost-en, håp-et,

3 sol-en, regn-et, ild-en, frost-en, håp-et,

Anna

Esther

Abdullah Mu-ham-med har be-fridd oss, det-te er ik-ke A - bra - ham men en C I A a-

Vln. A

Vln.+div

Vln. I

Vln. 2

Vla.

Vc.

Cb.

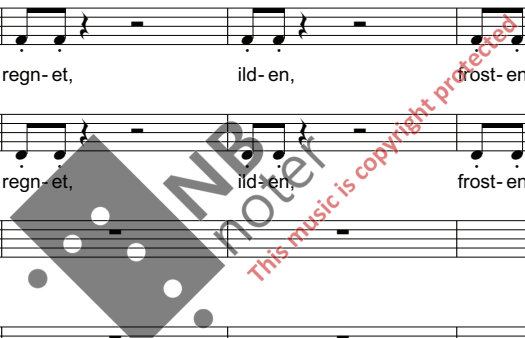

Fl. *f* *mp*

Cl. *f* *mp*

Gtr.

tar

synth *piano* *mp*

Accord. *f*

1 *f*  
Is-ak. Mo - ri - a.

2 *f*  
Is-ak. Mo - - a,

3 *f*  
Is-ak. Mo - - a

Anna

Esther Gud er en barm-hjer - tig Gud, ret - fer -

Abdullah gent i for-kled ning,

Vln. A *f* *mp* pizz

Vln.+div *f* *mp* pizz

Vln. I *f* *mp* pizz

Vln. 2 *f* *mp* pizz

Vla. *f* *mp* pizz

Vc. *f* *mp* pizz

Cb. *f* *mp*

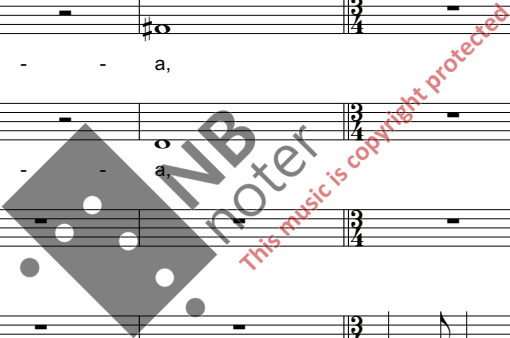

Fl.

Cl.

Gtr.

tar

synth

Accord.

1

2

3

Anna

Esther

Abdullah

Vln. A

Vln.+div

Vln. I

Vln. 2

Vla.

Vc.

Cb.



Fl. *f*

Cl. *f*

Gtr. *f*

tar

synth *f*

Accord. *f*

1 *f*

2 *f*

3 *f*

Anna *f*

Esther *f*

Abdullah *f*

Vln. A *f*

Vln.+div *f*

Vln. I *f*

Vln. 2 *f*

Vla. *f*

Vc. *f*

Cb. *f*

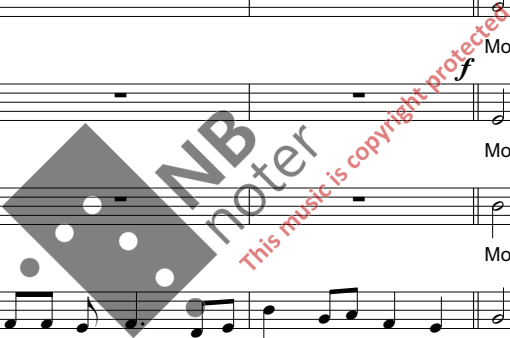

Mo - ri - a.

Mo - ri - a

Mo - ri - a.

Mo - ri - a.

A - bra-ham, men en mus-limsk ter-ror-ist i for-kled-ning. Mo - ri - a

Mo - ri - a.

arco

*f* arco

*f*

arco

*mp*

*f*

arco

*mp*

*mp* arco

*mp*

*f*

# Sterkeste grenen del 8

Bertil Palmar Johansen  
Terje Nordby

♩ = 72

The score is for a 4/4 piece with a tempo of 72 beats per minute. It features a variety of instruments and vocalists. The flute and guitar play a melodic line starting with a half note G4, followed by quarter notes A4, B4, and C5. The clarinet in Bb and synth play a similar line but with a lower register. The accordion and violin parts provide harmonic support. The string section includes violin A, violin I, violin II, viola, and violoncello. The contrabass plays a bass line starting with a half note G2, followed by quarter notes A2, B2, and C3. The vibraphone plays a rhythmic pattern. The vocalists Esther/Anna and Abdullah have lyrics in Norwegian.

**Flute** *mp*

**Clarinet in B $\flat$**  *mp*

**Guitar** *mp*

**Tar**

**Synth** *el. piano mp*

**Accordion** *mp*

**Triangle**

**Cabasa**

**Congas**

**Wood Block**

**Vibraphone** *senza motor p*

**Esther/Anna** *Ester:*  
Men om stem-men var A-bra-ham så spør jeg: Hva

**Abdullah**

**Violin A** *mp p*

**Viol+div** *mp*

**Violin I** *mp p*

**Violin II** *mp*

**Viola** *mp p*

**Violoncello** *mp p*

**Contrabass** *mf arco p*

Fl.

Cl.

Gtr.

tar

synth

Accord.

Tri.

Cab.

Congas

W.B.

Vib.

E/A   
 vil-le han med å be oss stan - se rei - sen til vi har til-gitt, til-gi hva da? Gud er

Abd.

Vln. A

Vln. +div

Vln. I

Vln. II

Vla.

Vc.

Cb.

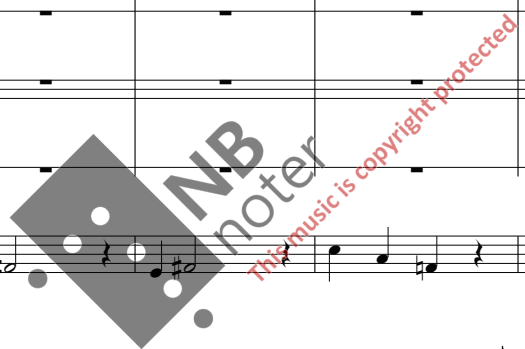

Fl.  *mf*

Cl. 

Gtr. 

tar 

synth 

Accord. 

Tri. 

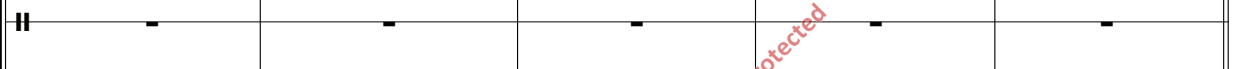
Cab. 

Congas 

W.B. 

Vib. 

E/A 

hard som fjell, krev-de hans barn, svar-et var ja, Som et tegn på lyd-ig het men søn-nen ble spart.

Abd. 

Vln. A 

Vln. +div 

Vln. I 

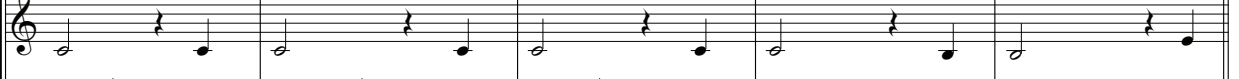
Vln. II 

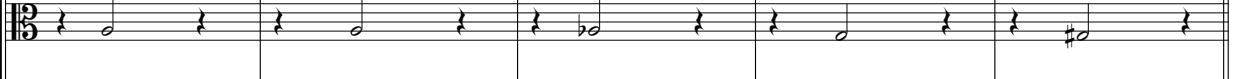
Vla. 

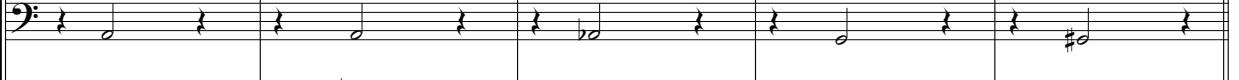
Vc. 

Cb. 

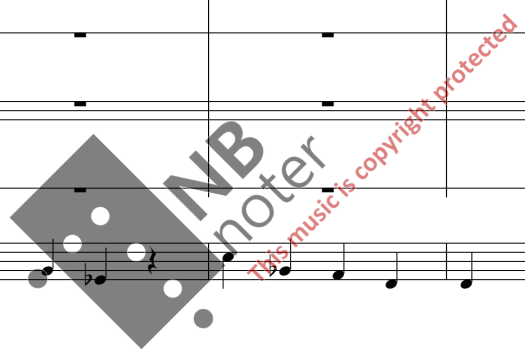



Fl. *mf* *p*

Cl. *mf* *p*

Gtr. *mp*

tar

synth *mf* *p* el piano

Accord. *mf*

Tri.

Cab.

Congas *mp*

W.B.

Vib. *mp* *p*

E/A Esther/Anna  
Lyd - gi - het, lyd - ig - het, lk-ke spør han, Her-ren vet det.

Abd. *mf*  
Lyd - ig - het, lyd - ig - het, lk-ke spør han, Her-ren vet det. Det fin-nes

Vln. A *mf*

Vln. +div *mf*

Vln. I *mf* *p*

Vln. II *mf* *p*

Vla. *mf* *p* arco

Vc. *mf* *p* arco

Cb. *mf* *p*



Fl.

Cl.

Gtr.

tar

synth

Accord.

Tri.

Cab.

Congas

W.B.

Vib.

E/A

Abd.   
 en Gud, han som rår ov - er alt som vi vet om, en Gud som er stor, Han hør-te guds røst, han hør-te

Vln. A

Vln. +div

Vln. I

Vln. II

Vla.

Vc.

Cb.

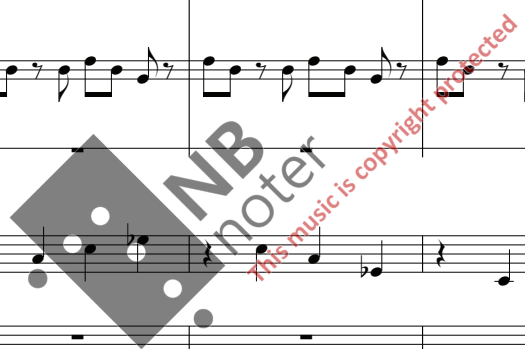

Fl.

Cl.

Gtr.

tar

synth

Accord.

Tri.

Cab.

Congas

W.B.

Vib.

E/A

Abd.

Vln. A

Vln. +div

Vln. I

Vln. II

Vla.

Vc.

Cb.

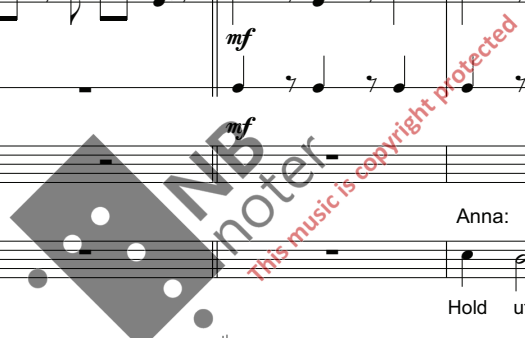

Fl.

Cl.

Gtr.

tar

synth

Accord.

Tri.

Cab.

Congas

W.B.

Vib.

E/A   
 Is - ak har vi holdt ut, barn av A-bra - ham, vi har gått med ham til fjel-let for å ofr-es, har vi gått lyd-ig

Abd.   
 stå, ik - ke gjen - ta nå hans of - fer. Ik - ke of - fre A-bra-hams barn.

Vln. A

Vln. +div

Vln. I

Vln. II

Vla.

Vc.

Cb.

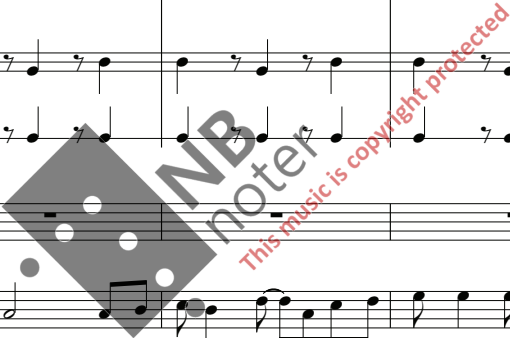

Fl.

Cl.

Gtr.

tar

To Harm.

synth

Accord.

Tri.

Cab.

Congas

W.B.

Vib.

E/A

med. Bom - be - drønn og flykt - ning - er, knust og drept og luft - an - grep, et - ter - slep.

Abd.

Bom - be - drønn og flykt - ning - er, knust og drept og luft - an - grep, et - ter - slep.

Vln. A

Vln. + div

Vln. I

Vln. II

Vla.

Vc.

Cb.

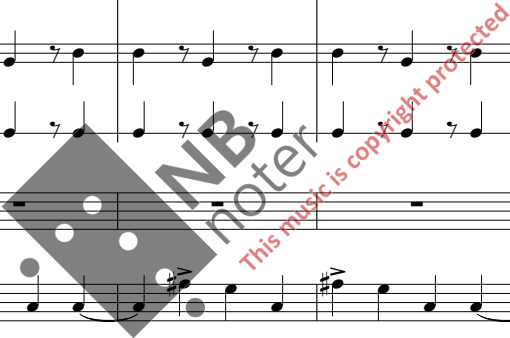

Fl. *f*

Cl. *f*

Gtr. *f*

tar

synth

Harmonica

Accord. *f* *ppp*

Tri.

Cab. *f*

Congas

W.B. *f*

Vib. *f*

E/A

Abd.

Vln. A *f* pizz

Vln. +div *f* arco

Vln. I *f* pizz

Vln. II *f* pizz

Vla. *f* pizz

Vc. *f* pizz

Cb. *f* pizz

Vi kjem - per for sam-me gud, Vi of - rer vå-re barn. Fel-les barn,  
 Vi kjem - per for sam-me gud, Vi of - rer vå-re barn. Fel-les barn,



Fl. *mp*

Cl.

Gtr. *mp*

tar

Harm.

Accord.

Tri.

Cab.

Congas

W.B.

Vib. *p*

E/A

vå-re barn. Ster - kes - te gre-nen på tre-et det er den som bøy es

Abd.

vå-re barn.

Vln. A *arco mp*

Vln. +div *mp arco*

Vln. I *mp arco*

Vln. II *mp arco*

Vla. *mp arco*

Vc. *mp arco*

Cb. *mp*

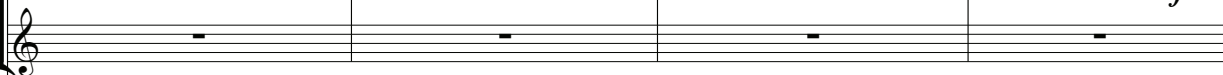

Fl. 

Cl. 

Gtr. 

tar 

Harm. 

Accord. 

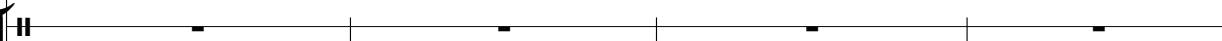
Tri. 

Cab. 

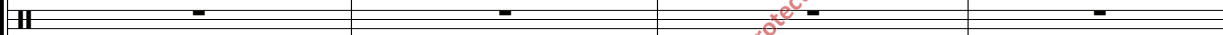
Congas 

W.B. 

Vib. 

E/A 

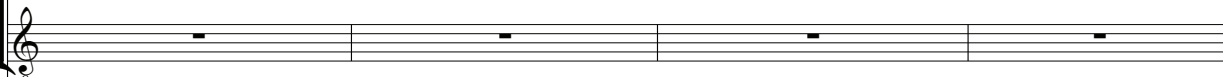
Abd. 

Vln. A 

Vln. +div 

Vln. I 

Vln. II 

Vla. 

Vc. 

Cb. 

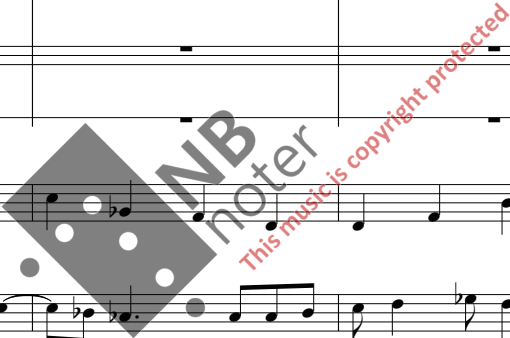



Fl.

Cl.

Gr.

tar

Harm.

Accord.

Tri.

Cab.

Congas

W.B.

Vib.

E/A   
 +kor Bø - er seg, yd - myk - het, bø - er seg, kjær - lig - het.

Abd.

Vln. A

Vln. +div

Vln. I

Vln. II

Vla.

Vc.

Cb.



# Isak er vår bror del 9

Bertil Palmar Johansen  
Terje Nordby

♩ = 142

This musical score is for the piece "Isak er vår bror del 9" by Bertil Palmar Johansen and Terje Nordby. It is in 4/4 time with a tempo of 142 beats per minute. The score includes parts for Piccolo, Clarinet in B $\flat$ , Guitar, Tar, Synth, Accordion, Side Drum, Triangle, Tabla, Marimba, Esther/Anna, Abdullah, Violin A, Viol+div, Violin 1, Violin 2, Viola, Violoncello, and Contrabass. The music features a variety of dynamics including *f*, *ff*, *mf*, and *pizz*. There are also performance markings such as accents, slurs, and triplets. A watermark for "NB noter.no" is visible across the score, along with a red diagonal line and the text "This music is copyright protected".

6

Picc. *ff* *mf*

Cl. *ff* *mf*

Gtr. *ff*

Tar. *ff*

synth *ff* *mf*

Accord. *mf*

S. D. *mf*

Tri. *mf*

Tabla *mf*

Mar. *ff*

Es/An

Abd.

Vln. A *ff* *mf*

Vln. +div

Vln. 1 *ff* *mf*

Vln. 2 *ff* *mf*

Vla. *ff* *mf*

Vc. *ff* *mf*

Cb. *ff* *mf*

Picc. *ff*

Cl. *ff*

Gtr. *ff* 3

Tar. *ff* 3

synth *ff*

Accord. *mf* *ff* *mf* *ff*

S. D.

Tri. *f*

Tabla *ff* *f*

Mar. *ff* 3

Es/An

Abd.

Vln. A *ff*

Vln. +div

Vln. 1 *ff*

Vln. 2 *ff*

Vla. *ff*

Vc. *ff*

Cb. *ff*

Picc.   
 Cl.

Gtr.   
 Tar.

synth

Accord.

S. D.

Tri.

Tabla

Mar.

Es/An.   
 Abd.

Esther:  
 A-bra-ham vis-te lyd - ig-het,

Vln. A   
 Vln. +div

Vln. 1

Vln. 2

Vla.

Vc.

Cb.

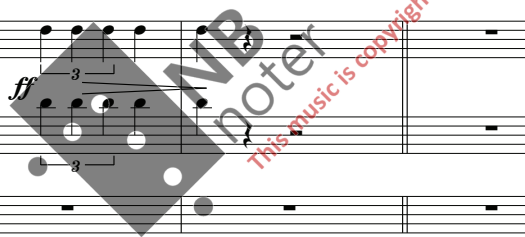

Picc.

Gr.

synth

Accord.

S. D.

Mar.

Es/An   
 ik-ke spør, Her-ren vet. Han tok oss med, han lei-de oss til Mo - ri - a. Det-te var vei-en vi måt-te  
 Abd.

Vln. A *mp*

Vln. +div

Vln. 1 *mp*

Vln. 2 *mp*

Vla. *mp*

Vc. *mp*

Cb. *mp*

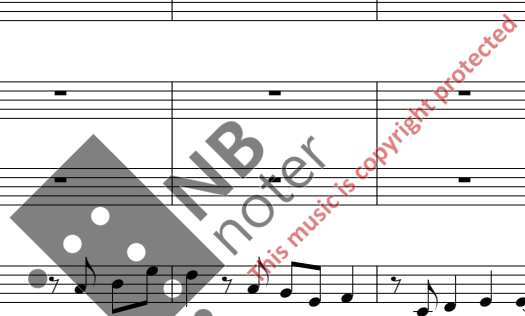

Picc.

Cl.

Gtr.

Tar.

synth

Accord.

S. D.

Tri.

Tabla

Mar.

Es/An

Abd.

To - day he asks us \_\_\_ to an-der-stand: For-give, don't do it a - gain now.

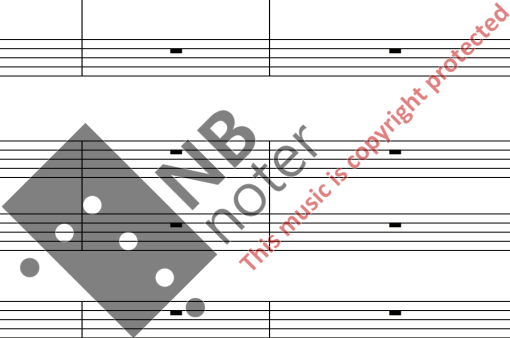

Vln. A

Vln. +div

Vln. 1

Vln. 2

Vla.

Vc.

Cb.

Picc.

Cl.

Gtr.

Tar.

synth

Accord.

S. D.

Tri.

Tabla

Mar.

Es/An

Abd.

Anna:  
We have en-dured, for

Vln. A

Vln. +div

Vln. 1

Vln. 2

Vla.

Vc.

Cb.

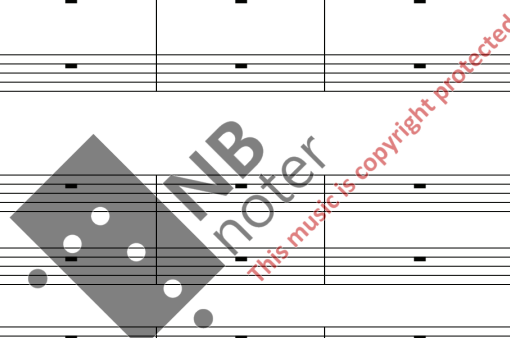





♩ = 142

Picc. *f*

Cl. *f*

Gtr. *ff* 3

Tar. *ff* 3

synth *f* *ff* 3

Accord. *mf* *ff*

S. D. *f*

Tri. *f*

Tabla *f*

Mar. *ff* 3

Es/An *f* kor inn valgf. toneart

Abd. A-bra-ham was o - be-di-ent.

♩ = 142

Vln. A *f*

Vln. +div vokal (Oluf)

Vln. 1 *f*

Vln. 2 *f*

Vla. *f*

Vc. *f*

Cb. *f* pizz



Picc. *mf* *ff*

Cl. *mf* *ff*

Gtr. *ff*

Tar. *ff*

synth *mf* *ff*

Accord. *mf* *ff* *mf* *ff*

S. D. *mf*

Tri. *ff*

Tabla *mf*

Mar. *ff*

Es/An

Abd.

Vln. A *mf*

Vln. + div

Vln. 1 *mf*

Vln. 2 *mf*

Vla. *mf*

Vc. *mf*

Cb. *mf* *ff*

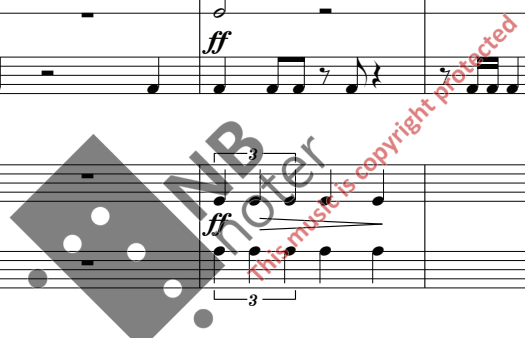

Picc. *ff*

Cl. *ff*

Gtr. *ff*

Tar. *ff*

synth *ff*

Accord. *mf*

S. D. *f*

Tri. *f*

Tabla *f*

Mar. *ff*

Es/An

Abd.

Vln. A *ff*

Vln. +div

Vln. 1 *ff*

Vln. 2 *ff*

Vla. *ff*

Vc. *ff*

Cb. *ff*

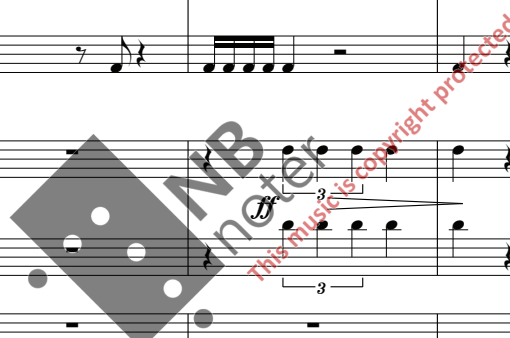

Picc.

Cl.

Gtr.

Tar.

synth

Accord.

S. D.

Tri.

Tabla

Mar.

Es/An

Abd.

Vln. A

Vln. +div

Vln. 1

Vln. 2

Vla.

Vc.

Cb.

This music is copyright protected

Picc.

Gr.

synth

Accord.

S. D.

Tri.

Tabla

Mar.

Es/An

Abd.

Vln. A

Vln. +div

Vln. 1

Vln. 2

Vla.

Vc.

Cb.

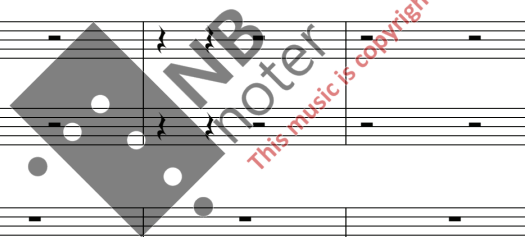

kor hold fermate

# El pelegrino del 10

Bertil Palmar Johansen

♩ = 310

Score for *El pelegrino del 10* by Bertil Palmar Johansen. The score is in 7/8 time and includes the following instruments and parts:

- Flute**: *mf*
- Clarinet in B $\flat$** : *mf*
- Guitar**: *mf*
- Tar**: *mf*
- Synth**: *mf*
- Accordion**: *mf*
- Tenor Drum**: *mf*
- Kidi**: *mf*
- Handclap**: *mf*
- Tambourine**: *mf*
- Violin A**: *mf*
- Vio+div**: *mf*
- Violin 1**: *mf* pizz, arco
- Violin 2**: *mf* pizz, arco
- Viola**: *mf* pizz, arco
- Violoncello**: *mf* pizz, arco
- Contrabass**: *mf* pizz

The score features a central watermark: **MB noter** with the text "This music is copyright protected".



Fl.

Cl.

Gtr.

tar

synth

Accord.

T. D.

Kidi

H.C.

Tamb.

Vln. A

Vln+div

Vln. 1

Vln. 2

Vla.

Vc.

Cb.

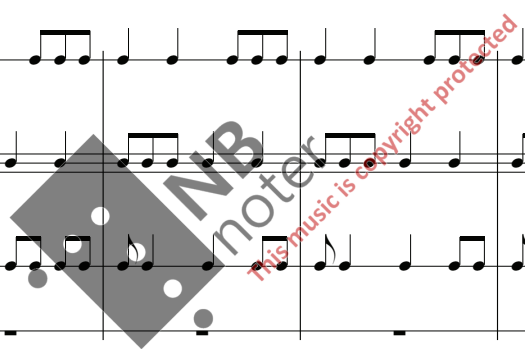

13

Fl. fløyte *mf*

Cl. *f*

Gtr. *f* *mf*

tar

synth *f* *mf*

Accord. *f* *mf*

T. D. *f* *mf*

Kidi *f* *mf*

H.C. *f* *mf*

Tamb.

Vln. A pizz *f* *mf*

Vln+div *f* *mf*

Vln. 1 arco *f* *mf* pizz

Vln. 2 pizz *f* *mf*

Vla. *f* *mf*

Vc. pizz *f* *mf*

Cb. *f* *mf* pizz

Fl.

Cl.

*f*

Gtr.

tar

*f*

synth

Accord.

*mf*

T. D.

Kidi

H.C.

Tamb.

*f*

Vln. A

Vln+div

Vln. 1

Vln. 2

Vla.

Vc.

Cb.

*f*

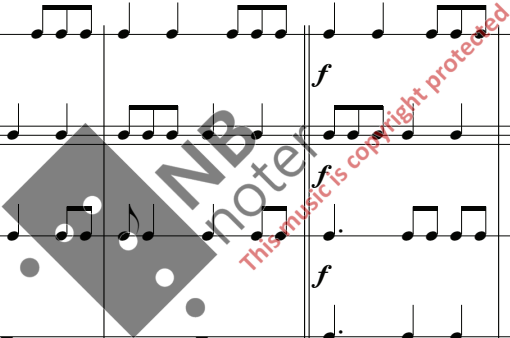



Fl.

Cl.

Gtr.

tar

synth

Accord.

T. D.

Kidi

H.C.

Tamb.

Vln. A

Vln+div

Vln. 1

Vln. 2

Vla.

Vc.

Cb.

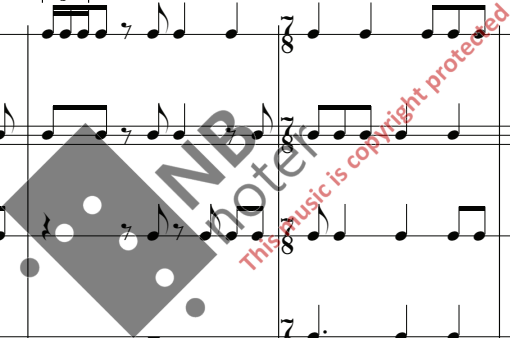

Fl.

Cl.

Gtr.

tar

synth

Accord.

T. D.

Kidi

H.C.

Tamb.

Vln. A

Vln+div

Vln. 1

Vln. 2

Vla.

Vc.

Cb.

*mf*

NB noter  
This music is copyright protected

kromhorn

Fl. *f*

Cl.

Gtr. *f*

tar

synth *f*

arabic

Accord. *f*

T. D.

Kidi

H.C.

Tamb. *f*

Vln. A *f*

Vln+div *f* pizz

Vln. 1 *f* pizz

Vln. 2 *f* pizz

Vla. *f* pizz

Vc. *f* pizz

Cb. *f*

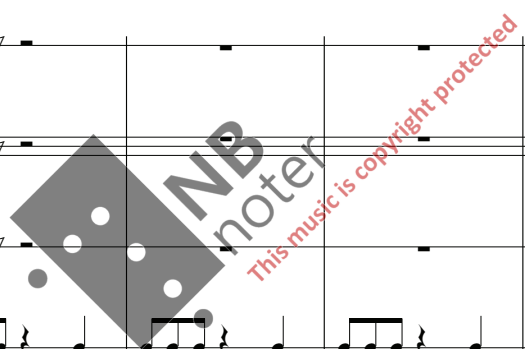

This musical score is arranged for a large ensemble. The instruments and their parts are as follows:

- Bagp.:** Bagpipes, playing a melodic line in the first system.
- Cl.:** Clarinet, playing a rhythmic accompaniment starting in the second system.
- Gtr.:** Guitar, playing a rhythmic accompaniment.
- tar:** Tar, which is silent throughout the score.
- synth:** Synthesizer, playing a melodic line in the first system.
- Accord.:** Accordion, playing a rhythmic accompaniment.
- T. D.:** Tenor Drums, playing a rhythmic pattern with triplets in the second system.
- Kidi:** Kidi, playing a rhythmic accompaniment.
- H.C.:** Harmonium, playing a rhythmic accompaniment.
- Tamb.:** Tambourine, playing a rhythmic accompaniment.
- Vln. A:** Violin A, playing a melodic line.
- Vln+div:** Violin and Diva, playing a rhythmic accompaniment.
- Vln. 1:** Violin 1, playing a rhythmic accompaniment.
- Vln. 2:** Violin 2, playing a rhythmic accompaniment.
- Vla.:** Viola, playing a rhythmic accompaniment.
- Vc.:** Violoncello, playing a rhythmic accompaniment.
- Cb.:** Contrabass, playing a rhythmic accompaniment.

The score is divided into two systems. The first system (measures 1-3) features the Bagp., Cl., Gtr., synth, and Accord. parts. The second system (measures 4-6) features the T. D., Kidi, H.C., Tamb., Vln. A, Vln+div, Vln. 1, Vln. 2, Vla., Vc., and Cb. parts. Dynamics include *f* (forte) and *ff* (fortissimo).





1. 2.

Bagp.

Cl.

Gtr.

tar

synth

Accord.

T. D.

Kidi

H.C.

Tamb.

Vln. A

Vln+div

Vln. 1

Vln. 2

Vla.

Vc.

Cb.

*This music is copyright protected*

# Lux illuxit del 11

arr Bertil Palmar Johansen

♩ = 52

The musical score is arranged in a vertical stack of staves. From top to bottom, the instruments and parts are: **SAMPL.** (Sample), **SYNTH.** (Synthesizer), **ACCORDION**, **CROTALES** (Crotales), **GLOCKENSPIEL** (Glockenspiel), **VIBRAPHONE**, **KOR** (Choir), **VIOLIN A**, **VIOL+DIV** (Violin/Divisi), **VIOLIN I**, **VIOLIN II**, **VIOLA**, **VIOLONCELLO** (Violoncello), and **CONTRABASS** (Contrabass). The score is in 4/4 time with a key signature of three flats (B-flat, E-flat, A-flat). Dynamics include *mp* (mezzo-piano), *p* (piano), and *pizz* (pizzicato). The choir part includes the lyrics "Lux illuxit- i raskere tempo". A large watermark "NB noter" is overlaid on the score, along with the text "This music is copyright protected".

samp.

Synth

Accord.

Crot.

Glock.

Vib.

kor

Vln. A

Vln. +div

Vln. I

Vln. II

Vla.

Vc.

Cb.

kor fortsetter satsen ut - kort pause mellom versene

**NB**  
noter  
This music is copyright protected

8

samp.

Synth

Accord.

Crot.

Glock.

Vib.

kor

Vln. A

Vln. +div

Vln. I

Vln. II

Vla.

Vc.

Cb.

arco

*p*

Detailed description of the musical score: The score is for page 129, starting at measure 8. It features 13 staves. The top staff is for 'samp.' (sampler) in treble clef. The next two staves are for 'Synth' (synthesizer) in treble and bass clefs. The 'Accord.' (accordion) staff is in treble clef. The 'Crot.' (crotales) staff is in treble clef. The 'Glock.' (glockenspiel) staff is in treble clef. The 'Vib.' (vibraphone) staff is in treble clef. The 'kor' (cor) staff is in treble clef. The 'Vln. A' (violin A) staff is in treble clef. The 'Vln. +div' (violin + divisi) staff is in treble clef. The 'Vln. I' (violin I) staff is in treble clef. The 'Vln. II' (violin II) staff is in treble clef. The 'Vla.' (viola) staff is in alto clef. The 'Vc.' (viola) staff is in bass clef. The 'Cb.' (double bass) staff is in bass clef. A watermark 'NB noter' is overlaid on the Vln. A staff. The double bass part has 'arco' and 'p' markings.

12

samp.

Synth

mf

mp

mf

mf

mf

mf

Vln. A

Vln. +div

Vln. I

Vln. II

Vla.

Vc.

Cb.

mf

16

samp.

Synth

mf

Accord.

Crot.

Glock.

Vib.

kor

Vln. A

*p*

*mf*

Vln. +div

*p*

*mf*

Vln. I

*p*

*mf*

Vln. II

*p*

*mf*

Vla.

*p*

*mf*

Vc.

*p*

Cb.

*p*

This image shows a page of a musical score, page 131, starting at measure 16. The score is arranged in a standard orchestral layout with multiple staves. The instruments listed on the left are: samp. (sampler), Synth (synthesizer), Accord. (accordion), Crot. (crotales), Glock. (glockenspiel), Vib. (vibraphone), kor (cor Anglais), Vln. A (violin A), Vln. +div (violin + divisi), Vln. I (violin I), Vln. II (violin II), Vla. (viola), Vc. (violin), and Cb. (cello). The key signature is three flats (B-flat, E-flat, A-flat), and the time signature is 3/8. The score includes various musical notations such as notes, rests, slurs, and dynamic markings. Dynamics include *p* (piano) and *mf* (mezzo-forte). A watermark 'NB noter' is overlaid on the score, with the text 'This music is copyright protected' written in red below it.

samp.

Synth

Accord.

Crot.

Glock.

Vib.

kor

Vln. A

Vln. +div

Vln. I

Vln. II

Vla.

Vc.

Cb.

*mf*

*f*

*p*

*mf*

This music is copyright protected



24

Musical score for page 133, measures 24-27. The score includes parts for samp., Synth, Accord., Crot., Glock., Vib., kor, Vln. A, Vln. +div, Vln. I, Vln. II, Vla., Vc., and Cb. Dynamics range from p to f.

**Instrumentation:** samp., Synth, Accord., Crot., Glock., Vib., kor, Vln. A, Vln. +div, Vln. I, Vln. II, Vla., Vc., Cb.

**Measures:** 24, 25, 26, 27

**Dynamics:** p, f

**Watermark:** NB noter, This music is copyright protected



32

The musical score is arranged in a vertical stack of staves. The instruments are: samp. (sample), Synth (synthesizer), Accord. (accordion), Crot. (crochets), Glock. (glockenspiel), Vib. (vibraphone), kor (kora), Vln. A (Violin A), Vln. +div (Violin + divisi), Vln. I (Violin I), Vln. II (Violin II), Vla. (Viola), Vc. (Violoncello), and Cb. (Cello). The score includes various musical notations such as notes, rests, and slurs. A large watermark 'NB noter' is overlaid on the center of the page, with the text 'This music is copyright protected' written in red below it.

*p*

37

Musical score for page 136, measures 37-40. The score includes parts for samp., Synth, Accord., Crot., Glock., Vib., kor, Vln. A, Vln. +div, Vln. I, Vln. II, Vla., Vc., and Cb. A watermark 'NB noter' is present over the strings.

**Instrumental Parts:**

- samp.:** Treble clef, melodic line with eighth and sixteenth notes.
- Synth:** Treble and Bass clefs, sustained notes with a forte (*f*) dynamic.
- Accord.:** Treble clef, sustained notes with a forte (*f*) dynamic.
- Crot.:** Treble clef, rhythmic pattern of eighth notes.
- Glock.:** Treble clef, sustained notes.
- Vib.:** Treble clef, melodic line with eighth notes.
- kor:** Treble clef, empty staff.
- Vln. A:** Treble clef, sustained notes with a forte (*f*) dynamic.
- Vln. +div:** Treble clef, sustained notes with a forte (*f*) dynamic.
- Vln. I:** Treble clef, sustained notes with a forte (*f*) dynamic.
- Vln. II:** Treble clef, sustained notes with a forte (*f*) dynamic.
- Vla.:** Bass clef, sustained notes with a forte (*f*) dynamic.
- Vc.:** Bass clef, sustained notes with a forte (*f*) dynamic.
- Cb.:** Bass clef, sustained notes with a forte (*f*) dynamic.

41

The musical score is arranged in a standard orchestral layout. The instruments and their parts are as follows:

- samp.:** Sampled instrument, treble clef, playing a melodic line with eighth and sixteenth notes.
- Synth:** Synthesizer, treble and bass clefs, playing sustained notes with dynamics *p* and *mf*.
- Accord.:** Accordion, treble clef, playing sustained notes with dynamics *p* and *mf*.
- Crot.:** Crotales, treble clef, playing a rhythmic pattern of eighth notes.
- Glock.:** Glockenspiel, treble clef, playing a rhythmic pattern of eighth notes.
- Vib.:** Vibraphone, treble clef, playing a melodic line with eighth notes.
- kor:** Kora, treble clef, with a whole rest.
- Vln. A:** Violin A, treble clef, playing sustained notes with dynamics *p* and *mf*.
- Vln. +div:** Violin + divisi, treble clef, playing sustained notes with dynamics *p* and *mf*.
- Vln. I:** Violin I, treble clef, playing sustained notes with dynamics *p* and *mf*.
- Vln. II:** Violin II, treble clef, playing sustained notes with dynamics *p* and *mf*.
- Vla.:** Viola, alto clef, playing sustained notes with dynamics *p* and *mf*.
- Vc.:** Violoncello, bass clef, playing sustained notes with dynamics *p* and *mf*.
- Cb.:** Contrabasso, bass clef, playing sustained notes with dynamics *p* and *mf*.

The score includes various musical notations such as rests, slurs, and dynamic markings. A large watermark is present in the center of the page.

NB noter  
This music is copyright protected

45

The musical score for page 138, measures 45-48, is arranged in a multi-staff format. The instruments and their parts are as follows:

- samp.:** Treble clef, mostly rests with some activity in measure 48.
- Synth:** Treble and Bass clefs, playing sustained notes with a crescendo leading to a forte (*f*) dynamic in measure 48.
- Accord.:** Treble clef, playing sustained notes with a crescendo leading to a forte (*f*) dynamic in measure 48.
- Crot.:** Treble clef, playing a rhythmic pattern of eighth notes.
- Glock.:** Treble clef, playing a rhythmic pattern of eighth notes.
- Vib.:** Treble clef, playing a melodic line in measure 45.
- kor:** Treble clef, mostly rests.
- Vln. A:** Treble clef, playing sustained notes with a crescendo leading to a forte (*f*) dynamic in measure 48.
- Vln. +div:** Treble clef, playing sustained notes with a crescendo leading to a forte (*f*) dynamic in measure 48.
- Vln. I:** Treble clef, playing sustained notes with a crescendo leading to a forte (*f*) dynamic in measure 48.
- Vln. II:** Treble clef, playing sustained notes with a crescendo leading to a forte (*f*) dynamic in measure 48.
- Vla.:** Alto clef, playing sustained notes with a crescendo leading to a forte (*f*) dynamic in measure 48.
- Vc.:** Bass clef, playing sustained notes with a crescendo leading to a forte (*f*) dynamic in measure 48.
- Cb.:** Bass clef, playing sustained notes with a mezzo-forte (*mf*) dynamic.

A watermark for "NB noter" is visible across the center of the page, with the text "This music is copyright protected" written in red below it.

49

Musical score for page 139, measures 49-51. The score includes parts for samp., Synth, Accord., Crot., Glock., Vib., kor, Vln. A, Vln. +div, Vln. I, Vln. II, Vla., Vc., and Cb. Dynamics include *p*.



Musical score for page 140, rehearsal mark 52. The score includes staves for samp., Synth, Accord., Crot., Glock., Vib., kor, Vln. A, Vln. +div, Vln. I, Vln. II, Vla., Vc., and Cb. A watermark 'NB noter' is present.



# Ilden er tent del 12

Bertil Palmar Johansen  
Terje Nordby

$\text{♩} = 92$

Flute

Clarinet in B $\flat$

Guitar *mp*

Tar

Synth *mp*

Accordion

Bongos

Handclap

Congas

Anna

Esther

Abdullah

$\text{♩} = 92$

Violin A *mp*

Vio+div *mp*

Violin 1 *mp*

Violin 2 *mp*

Viola *mp*

Violoncello *mp*

Contrabass



7

Fl.

Cl.

Gtr.

tar

synth

Accord.

Bongos

H.C.

Congas

Anna

Esther

Abd.

Vln. A

Vln+div

Vln. 1

Vln. 2

Vla.

Vc.

Cb.

This music is copyright protected

Fl.

Cl.

Gtr.

tar

synth

Accord.

Bongos

H.C.

Congas

Anna

Esther

Abd.

Vln. A

Vln+div

Vln. 1

Vln. 2

Vla.

Vc.

Cb.

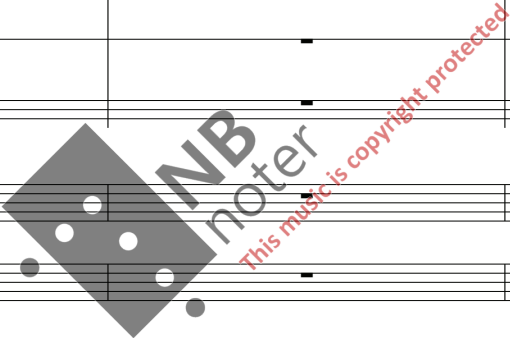

Fl.

Cl.

Gtr.

tar

synth

Accord.

Bongos

H.C.

Congas

Anna

Esther

Abd.

Vln. A

Vln+div

Vln. 1

Vln. 2

Vla.

Vc.

Cb.

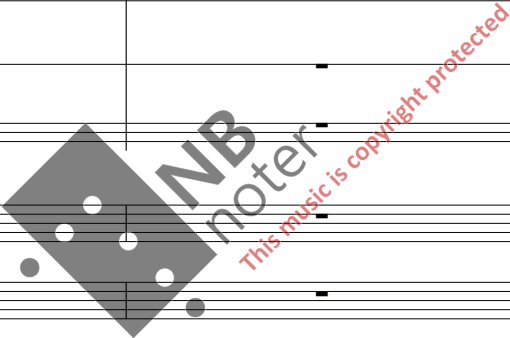

146

16

Fl.

Cl.

Gtr.

tar

synth

mp

Accord.

Bongos

H.C.

Congas

Anna

Esther

Abd.

En kjær - lig - hets - -

Vln. A

mp

Vln+div

mp

Vln. 1

mp

Vln. 2

mp

Vla.

mp

Vc.

Cb.

Fl.

Cl.

Gtr.

tar

synth

Accord.

Bongos

H.C.

Congas

Anna

Esther

Abd.

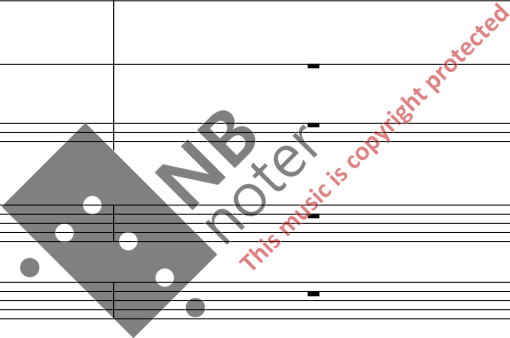

Vln. A

Vln+div

Vln. 1

Vln. 2

Vla.

Vc.

Cb.

Fl.

Cl.

Gtr.

tar

synth

Accord.

Bongos

H.C.

Congas

Anna

Esther

Abd.

ik - ke bud om of - fer el - ler krig.

Vln. A

Vln+div

Vln. 1

Vln. 2

Vla.

Vc.

Cb.

*mf*

**NB**  
noter  
This music is copyright protected



Fl.

Cl.

Gtr.

tar

synth

Accord.

Bongos

H.C.

Congas

Anna

Esther

Abd.

Vln. A

Vln+div

Vln. 1

Vln. 2

Vla.

Vc.

Cb.

*mf*

*f*

*mp*





Fl. 

Cl. 

Gtr. 

tar 

synth 

Accord. 

Bongos 

H.C. 

Congas 

Anna   
 vi rei-ser vi - de-re nå, Vi har for-stått og vi kan rei-se vi - de - re. Har gitt til -

Esther 

Abd. 

Vln. A 

Vln+div 

Vln. 1 

Vln. 2 

Vla. 

Vc. 

Cb. 



Fl.

Cl.

Gtr.

tar

synth

Accord.

Bongos

H.C.

Congas

Anna

Esther

Abd.

Vln. A

Vln+div

Vln. 1

Vln. 2

Vla.

Vc.

Cb.



Fl. *f*

Cl. *f*

Gtr.

tar

synth *f*

Accord.

Bongos

H.C.

Congas

Anna *f* +kor  
giv - el - se. Gud er her nå, Il-den er tent, La oss var - me oss ved

Esther *f* +kor  
Gud er her nå, Il-den er tent, La oss var - me oss ved

Abd. *f* +kor  
Gud er her nå, Il-den er tent, La oss var - me oss ved

Vln. A

Vln+div

Vln. 1 *f* pizz

Vln. 2 *f* pizz

Vla. *f* pizz

Vc. *f* pizz

Cb. *f*

*This music is copyright protected*

Fl. *f*

Cl. *f*

Gtr. *f*

tar *f*

synth *f*

Accord. *f*

Bongos *f*

H.C. *f*

Congas *f*

Anna  
bål - et, det er reis - en som er mål - et. Gud er her nå!

Esther  
bål - et, det er reis - en som er mål - et. Gud er her nå!

Abd.  
bål - et, det er reis - en som er mål - et. Gud er her nå!

Vln. A *f* arco

Vln+div *f*

Vln. 1 *f* arco

Vln. 2 *f* arco

Vla. *f* arco

Vc. *f* arco

Cb. *f*





Fl.

Cl.

Gtr.

tar

synth

Accord.

Bongos

H.C.

Congas

Anna

Esther

Abd.

Vln. A

Vln+div

Vln. 1

Vln. 2

Vla.

Vc.

Cb.

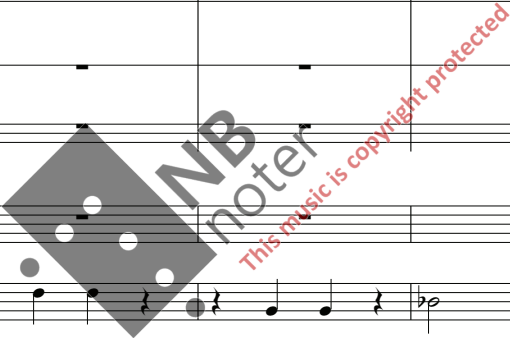





61 157

Fl.

Cl.

Gtr.

tar

synth

Accord.

Bongos

H.C.

Congas

Anna  
a, plea - sure, spe - ran - sa, a - van -

Esther  
ven - gi - a - mo. on and on on and on,

Abd.  
spe - ran - za va - mos, plea - sure,

Vln. A

Vln+div

Vln. 1

Vln. 2

Vla.  
*mp*

Vc.

Cb.

*This music is copyright protected*

Fl. *p*

Cl. *p*

Gtr. *mp*

tar

synth *mp*

Accord. *mp*

Bongos

H.C.

Congas

Anna

Esther  
ti, on and on, on and on, on and on, on and on,

Abd.  
a - van - ti, spe - ran - za, plea - sure,  
on and on, on and on, a - van - ti, ev - de - mo - ni - a, Kom, for det som

Vln. A *pp*

Vln+div *pp*

Vln. 1 *pp*

Vln. 2 *pp*

Vla. *pp*

Vc. *pp*

Cb. *pp*



Fl.   
 Cl.   
*p*

Gtr.   
 tar

synth

Accord.

Bongos   
 H.C.   
 Congas

Anna   
 Esther   
 Abd.   
 kom nå min venn, det hen - der nå,   
 Kom nå, kom nå, kom nå. Kom, for det som   
 skjer, det hen-der nå, og al - dri mer. Kom nå,

Vln. A   
 Vln+div   
 Vln. 1   
 Vln. 2   
 Vla.   
 Vc.   
 Cb.

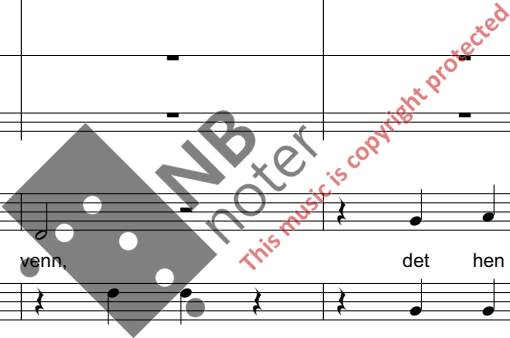

Fl.

Cl.

Gtr.

tar

synth

Accord.

Bongos

H.C.

Congas

Anna

Esther

Abd.

Vln. A

Vln+div

Vln. 1

Vln. 2

Vla.

Vc.

Cb.

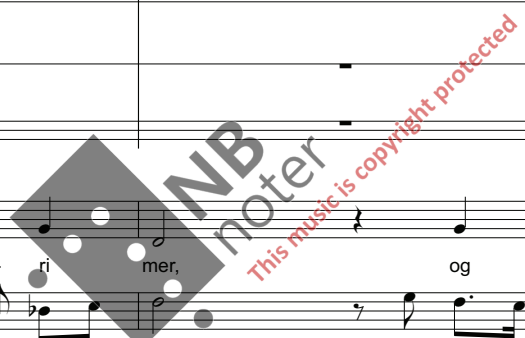

# Se det er dag del 13

161  
Bertil Palmar Johansen  
Terje Nordby

$\text{♩} = 104$

Flute

Clarinet in B $\flat$

Guitar *mf*

Tar

harp

Synth *mf*

Accordion *mp*

Cabasa

Tubular Bells

Anna

Esther/kor

Abdullah

Violin A *pizz*

Viol+div *pizz mf*

Violin 1 *pizz mf*

Violin 2 *pizz mf*

Viola *pizz mf*

Violoncello *mf pizz*

Contrabass *mf*

Se det er dag, vår - en gryr, vi

Fl. *mp*

Cl. *mp*

Gtr.

Ban.

Synth

Accord.

Cab.

Tub. B.

Anna

Esther/kor

Abdullah

frøs, vi vil frem, syn - ge nå, vå - ge nå, våp - en lø - se.

Vln. A

Vln. +div

Vln. 1

Vln. 2

Vla.

Vc.

Cb.

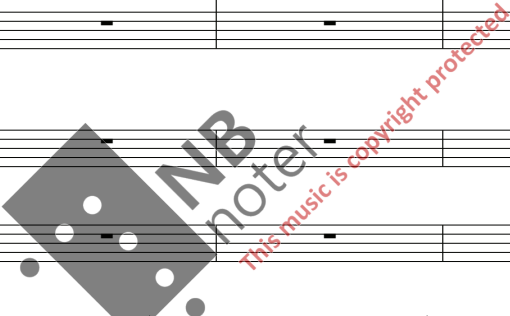

Fl.

Cl.

Gtr.

Ban.

synth

Accord.

Cab.

Tub. B.

Anna

Esther/kor

Abdullah

Vln. A

Vln. +div

Vln. 1

Vln. 2

Vla.

Vc.

Cb.

*mp*

*mp*

*mp*

*mp*

*mp*

*mp*

*mp*

*mp*

*mp*

*mp*

*mp*

Esther:

Mø-te deg med blik - ket,

Da - gen gryr.

våp - en - lø - se. Vår - en

Åp-ne opp til hver - and - re.

Mø-te deg med

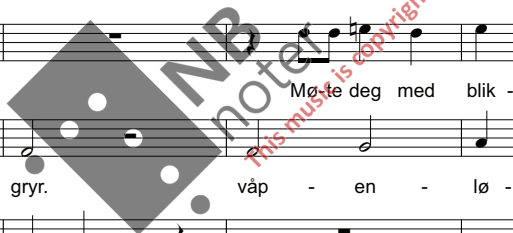

Fl. *mf*

Cl. *mf*

Gtr.

Ban.

synth *mf*

Accord. *p*

Cab.

Tub. B.

Anna

Esther/kor  
gryr, vi vil frem. Kor: Lux il - lux - it,

Abdullah  
lys - et. lk - ke mø - te med hat.

Vln. A

Vln. +div

Vln. 1 *mf*

Vln. 2 *mf*

Vla. *mf*

Vc. *mf*

Cb. *mf*





Fl. *mf*

Cl.

Gtr.

Ban.

synth

Accord.

Cab.

Tub. B.

Anna: At - ten - tat.

Esther/kor: Kor: Esther: kor: Lux - il - lux - it, Død - en på torg - et. Lux - il - lux - it,

Abdullah: Dø - den i en by.

Vln. A

Vln. + div

Vln. 1

Vln. 2

Vla.

Vc.

Cb.



26

Fl.

Cl.

Gtr.

Ban.

synth

Accord.

Cab.

Tub. B.

Anna

Esther/kor

Abdullah

Vi møt-te dø-den på en øy.

Lux - il - lux - it,

Hjelp oss lys, gle - dens lys.

Hjelp oss lys, gle - dens lys.

Hjelp oss lys, gle - dens lys.

Vln. A

Vln. +div

Vln. 1

Vln. 2

Vla.

Vc.

Cb.



Fl. *p*

Cl. *p*

Gtr.

Ban.

synth *p*

Accord. *p*

Cab.

Tub. B.

Anna *p*

Esther/kor *p*

Abdullah *p*

Lux - il - lux - it, Stå i - mot mørk - et, finn til -

Vln. A arco *p*

Vln. +div arco *p*

Vln. 1 arco *p*

Vln. 2 arco *p*

Vla. arco *p*

Vc. arco *p*

Cb. *p*

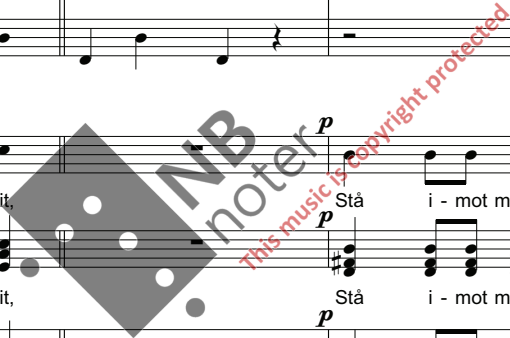

Fl.

Cl.

Gtr.

Ban.

synth

Accord.

Cab.

Tub. B.

Anna

Esther/kor

Abdullah

noen fraser fra  
jødisk vuggesang  
(svakt)

Vln. A

vuggesang  
noen fraser.  
svakt

Vln. +div

Vln. 1

Vln. 2

Vla.

Vc.

Cb.

# Hver vår stamme del 14

Bertil Palmar Johansen  
Terje Nordby

$\text{♩} = 184$

Flute

Clarinet in B $\flat$

Guitar *mf*

Tar

Synth *mf* string pizz

Accordion

Perc impr. *mp* Perc impr. visper

Handclap *mp*

Congas *mp*

Marimba *mp*

Anna

Esther

Abdullah

Violin A *mf* pizz

Viol+div *mf* pizz

Violin I *mf* pizz

Violin II *mf* pizz

Viola *mf* pizz

Violoncello *mf* pizz

Contrabass *mf*

Esther:  
Jeg er jø-de og

Fl.

Cl.

Gtr.

tar

Synth.

Accord.

perc imp.

H.C.

Congas

Mar.

Anna

Esther   
 du a - rab - er, vi kom - mer i fra, vi sprin - ger ut av hver vår stam - me, mus - lim og jø - de.

Abd.

Vln. A

Vln. +div

Vln. I

Vln. II

Vla.

Vc.

Cb.

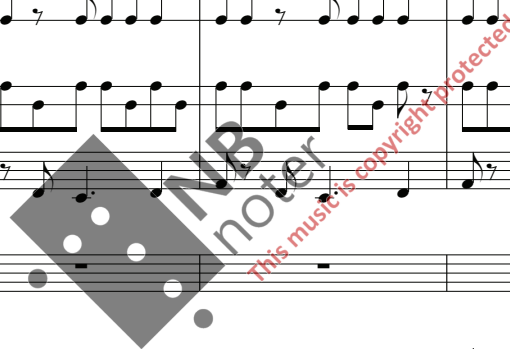

Fl.

Cl.

Gtr.

tar

Synth.

Accord.

perc imp.

H.C.

Congas

Mar.

Anna

Esther

Abd.

Vln. A

Vln. +div

Vln. I

Vln. II

Vla.

Vc.

Cb.

Hver vår stam - me. Stad - ig lær-te vi: Gud har all - tid holdt seg til oss.

Fl.

Cl.

Gtr.

tar

Synth.

Accord.

perc imp.

H.C.

Congas

Mar.

Anna

Esther

Abd.

Vln. A

Vln. +div

Vln. I

Vln. II

Vla.

Vc.

Cb.

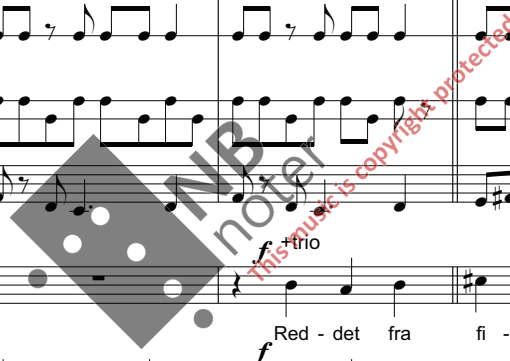





26

Fl.

Cl.

Gtr.

tar

Synth.

Accord.

perc imp.

H.C.

Congas

Mar.

Anna

Esther

Abd.

Vln. A

Vln. +div

Vln. I

Vln. II

Vla.

Vc.

Cb.

NB notel  
This music is copyright protected

Fl. *mf*

Cl. *mf*

Gtr. *mf*

tar

Synth. *mf*

Accord. *mf*

perc imp.

H.C.

Congas

Mar.

Anna

Esther

Abd.

Vln. A *mf*

Vln. +div

Vln. I *mf*

Vln. II *mf*

Vla. *mf*

Vc. *mf*

Cb. *mf*

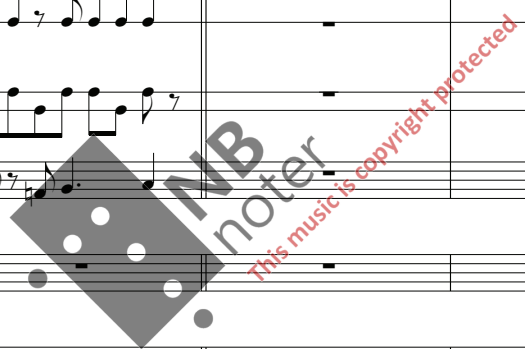

Fl.

Cl. *mp*

Gtr. *mp*

tar

Synth. *mp*

Accord. *mp*

perc imp.

H.C. *mp*

Congas *mp*

Mar.

Anna:

Anna *mp*  
 Hver en Gud har sagt det sam - me, brent det inn med

Esther

Abd.

Vln. A

Vln. +div *mp*

Vln. I *mp*

Vln. II *mp*

Vla. *mp*

Vc. *mp*

Cb. *mp*



Fl. 

Cl. 

Gtr. 

tar 

Synth. 

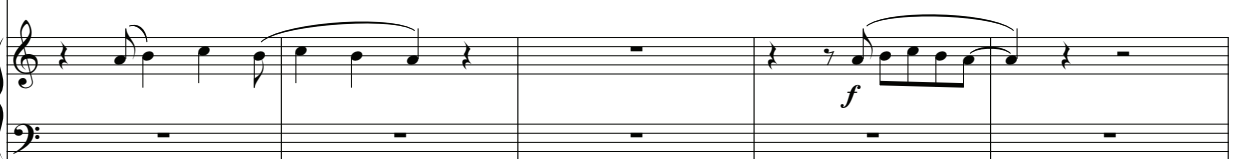
Accord. 

perc imp. 

H.C. 

Congas 

Mar. 

Anna 

Esther 

Abd. 

Vln. A 

Vln. +div 

Vln. I 

Vln. II 

Vla. 

Vc. 

Cb. 



Fl.

Cl.

Gtr.

tar

Synth.

Accord.

perc imp.

H.C.

Congas

Mar.

Anna

Esther

Abd.

Vln. A

Vln. +div

Vln. I

Vln. II

Vla.

Vc.

Cb.



Fl.

Cl.

Gtr.

tar

Synth.

Accord.

perc imp.

H.C.

Congas

Mar.

Anna

Esther

Abd.

Vln. A

Vln. +div

Vln. I

Vln. II

Vla.

Vc.

Cb.

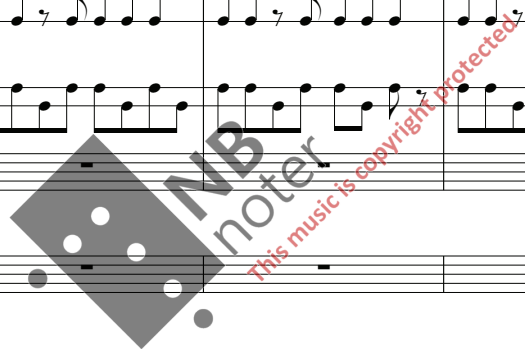

Fl.  *f*

Cl.  *f*

Gtr.  *f*

tar 

Synth.  *f*

Accord.  *f*

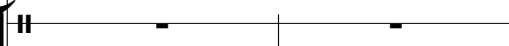
perc imp. 

H.C. 

Congas  *f*

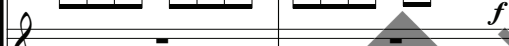
Mar. 

Anna  *f*

Esther  *f*

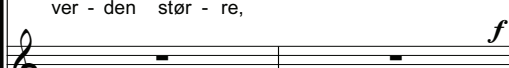
Abd.  *f*

Vln. A  *f*

Vln. +div  *f*

Vln. I  *f*

Vln. II  *f*

Vla.  *f*

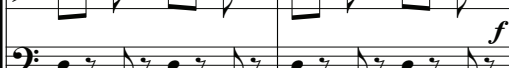
Vc.  *f*

Cb.  *f*

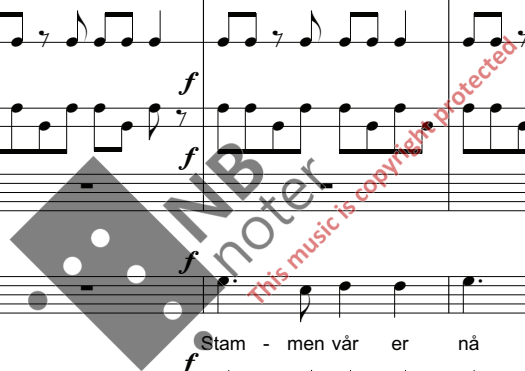

Stam - men vår er nå en del av al - le fol - ke -  
 ver - den stør - re, Stam - men vår er nå en del av al - le fol - ke -  
 Stam - men vår er nå en del av al - le fol - ke -



Fl.

Cl.

Gtr.

tar

Synth.

Accord.

perc imp.

H.C.

Congas

Mar.

Anna

Esther

Abd.

Vln. A

Vln. +div

Vln. I

Vln. II

Vla.

Vc.

Cb.

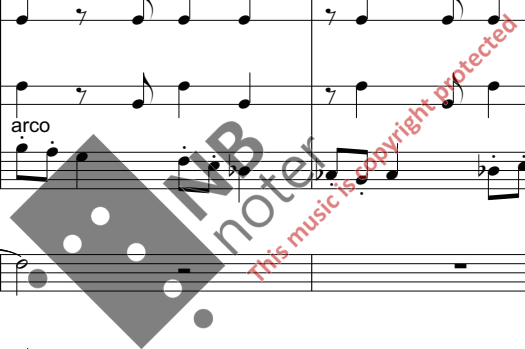

Fl.

Cl.

Gtr.

tar

Synth.

Accord.

perc imp.

H.C.

Congas

Mar.

Anna

Esther

Abd.

Vln. A

Vln. +div

Vln. I

Vln. II

Vla.

Vc.

Cb.

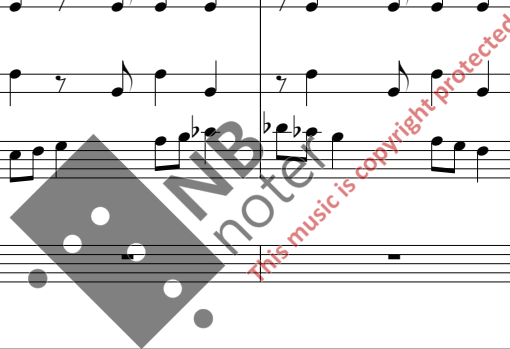

Fl.

Cl.

Gtr.

tar

Synth.

Accord.

perc imp.

H.C.

Congas

Mar.

Anna

Esther

Abd.

Vln. A

Vln. +div

Vln. I

Vln. II

Vla.

Vc.

Cb.

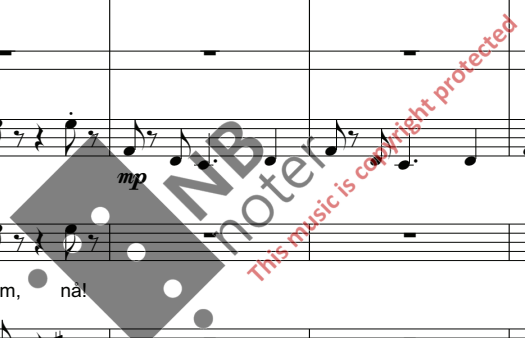

Fl.

Cl.

Gtr.

tar

Synth.

Accord.

perc imp.

H.C.

Congas *mp*

Mar. *mp*

Anna

Esther

Abd. *Abdullah:*  
 Du er jø-de og jeg a - ra-ber, vi stem-mer i med, vi syng-er ut med hver vår stem-me, mus

Vln. A

Vln. +div

Vln. I

Vln. II

Vla.

Vc.

Cb.



Fl.

Cl.

Gtr.

tar

Synth.

Accord.

perc imp.

H.C.

Congas

Mar.

Anna

Esther

Abd.

lim og jø-de, hver vår stem-me. Sta-dig lær-te vi: Gud har all-tid

Vln. A

Vln. +div

Vln. I

Vln. II

Vla.

Vc.

Cb.



Fl.

Cl.

Gtr.

tar

Synth.

Accord.

perc imp.

H.C.

Congas

Mar.

Anna

Red - det fra fi - en - den,

Esther

Red - det fra fi - en - den,

Abd.

holdt seg til oss, Elsk - et, refs-et, for-svart og red-det. Red - det fra fi - en - den,

Vln. A

Vln. + div

Vln. I

Vln. II

Vla.

Vc.

Cb.

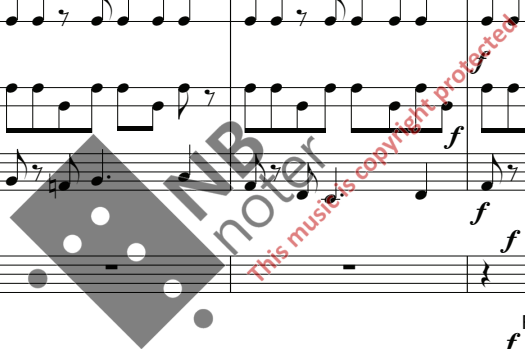

Fl. *ff*

Cl. *ff*

Gtr. *ff*

tar

Synth. *ff*

Accord. *ff*

perc imp.

H.C.

Congas

Mar. *ff*

Anna *kor tutti*

men hvem er fi - en - den? Se oss

Esther

men hvem er fi - en - den? Se oss

Abd.

men hvem er fi - en - den? Se oss

Vln. A *ff*

Vln. +div *ff*

Vln. I *ff*

Vln. II *ff*

Vla. *ff*

Vc. *ff*

Cb. *ff*

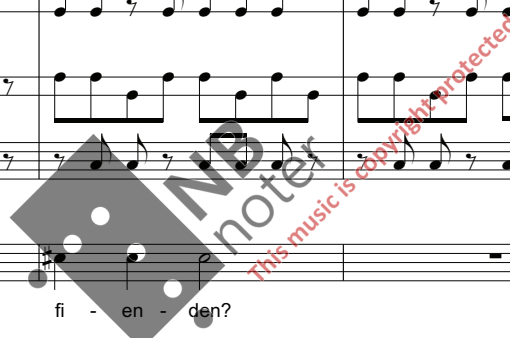

Fl.

Cl.

Gtr.

tar

Synth.

Accord.

perc imp.

H.C.

Congas

Mar.

Anna 

Esther 

Abd. 

Vln. A

Vln. +div

Vln. I

Vln. II

Vla.

Vc.

Cb.

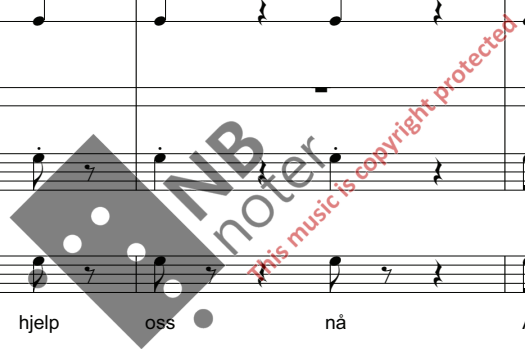



# Reisen er målet ditt del 15

Bertil Palmar Johansen  
Terje Nordby

$\text{♩} = 80$

Clarinet in B $\flat$

Guitar *mf*

Piano

Accordion *mp*

vl.+div

Glockenspiel

Vibraphone

Resiterer på gresk:\*

\* Når du setter ut på din reise til Ithaka,  
be at din ferd blir lang,  
full av eventyr, full av kunnskap.  
Be om at din ferd blir lang.

Når du setter ut på din reise til Ithaka.

\*\*ev bordun impro - Be at din reise blir lang,  
at de som i morgener må bli mange  
når du med denne glede, den ubeskrevne fryd  
kommer til havner du aldri har sett før:  
At du stanser ved fønikiske markeds plasser  
for å handle gode varer,  
perler, korall, ambra og elfenben  
og overdådige parfymen av alle slag,  
en så stor mengde overdådige parfymen du kan bære;  
at du reiser videre til mange egyptiske byer  
for å lære og så lære igjen av vismennene.

9

Cl.

Gtr.

Pno. *pp*

Accord. *p*

Vol.+div

Glock. m.strikkepinne

Vib.

17

Cl.

Gtr.

Pno.

Accord.

Vol.+div

Glock.

Vib.

*p*

Se til at rei - sen din blir lang. Bring med deg no - e fra hver en havn du

23

Cl.

Gtr.

Pno.

Accord.

Vol.+div

Glock.

Vib.

ankr - er opp, Gull, ko - ral - ler, som - mer - duft, vis - doms - ord. Lang - samt frem, for reis - en er mål - et

30

Cl.

Gtr.

Pno.

Accord.

Vol.+div

Glock.

Vib.

cl eller kor greg ( ev Halleluja).

resitasjon: \*\*

ditt.

38

Cl.

Gtr.

Pno.

Accord.

Vol.+div

Glock.

Vib.

*mf*

*p*

Ro - lig, la rei - sen din bli lang,

45

Cl.

Gtr.

Pno.

Accord.

Vol.+div

Glock.

Vib.

Lytt å pent og du vil hø - re ån - der

49

Cl.

Gtr.

Pno.

Accord.

Vol.+div

Glock.

Vib.

resiter:\*\*\* Forhast deg ikke på noen måte. La det vare mange år.  
til du, når du er gammel, ankrer opp ved din øy  
rik med alt du har fått på veien.

ta - le.



6

Fl.

Cl.

Gtr.

tar

synth

Accord.

Bongos

Gro.

H.C.

Congas

Anna

Esther

kor

Vln. A

Vln+div

Vln. 1

Vln. 2

Vla.

Vc.

Cb.

This music is copyright protected

This musical score page includes the following parts:

- Fl.** (Flute): Melodic line with various ornaments and dynamics.
- Cl.** (Clarinet): Melodic line with various ornaments and dynamics.
- Gtr. tar.** (Guitar): Rhythmic accompaniment with chords and single notes.
- synth** (Synthesizer): Two staves providing harmonic support.
- Accord.** (Accordion): Two staves providing harmonic support.
- Bongos**: Rhythmic pattern with accents.
- Gro.** (Conga): Rhythmic pattern with accents.
- H.C.** (Cajon): Rhythmic pattern with accents.
- Congas**: Rhythmic pattern with accents.
- Anna**: Vocal line (no notes).
- Esther**: Vocal line (no notes).
- kor**: Vocal line (no notes).
- Vln. A**: Violin A part, melodic line with ornaments.
- Vln+div**: Violin and Viola parts, rhythmic accompaniment.
- Vln. 1**: Violin 1 part, rhythmic accompaniment.
- Vln. 2**: Violin 2 part, rhythmic accompaniment.
- Vla.** (Viola): Rhythmic accompaniment.
- Vc.** (Violoncello): Rhythmic accompaniment.
- Cb.** (Contrabasso): Rhythmic accompaniment.

A watermark for "MIB noter" is visible across the center of the page, with the text "This music is copyright protected." written diagonally.



21

Fl. - - - - - *mp*

Cl. - - - - - *mp*

Gtr. *mp*

tar - - - - -

synth *mp*

Accord. - - - - -

Bongos

Gro. - - - - -

H.C. - - - - -

Congas *mp*

Anna  
vi har sam - me far, vi er A - bra-hams barn.

Esther  
vi har sam - me far, vi er A - bra-hams barn.

kor  
vi har sam - me far, vi er A - bra-hams barn,

Vln. A - - - - -

Vln+div - - - - -

Vln. 1 *mp* pizz

Vln. 2 *mp* pizz

Vla. *mp* pizz

Vc. *mp*

Cb. *mp*

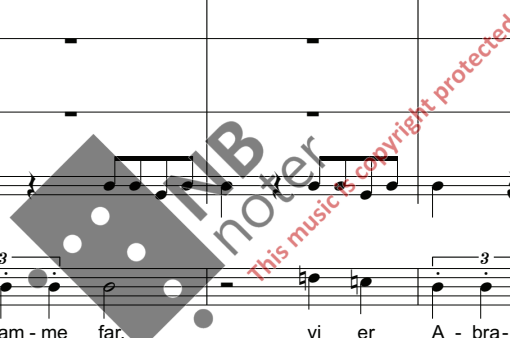



Fl.

Cl.

Gtr.

tar

synth

Accord.

Bongos

Gro.

H.C.

Congas

Anna

Esther

kor

Vln. A

Vln+div

Vln. 1

Vln. 2

Vla.

Vc.

Cb.



Fl.

Cl.

Gtr.

tar

synth

Accord.

Bongos

Gro.

H.C.

Congas

Anna

Esther

kor

Vln. A

Vln+div

Vln. 1

Vln. 2

Vla.

Vc.

Cb.

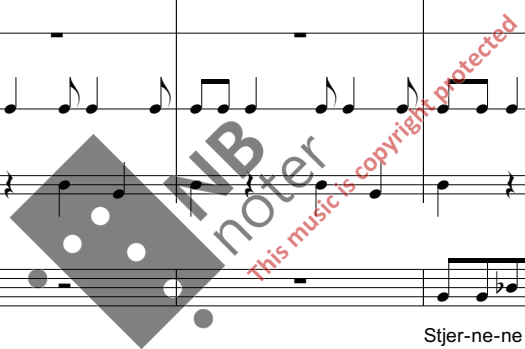

Fl. *mf*

Cl. *mf*

Gtr.

tar

synth *mf*

Accord.

Bongos

Gro.

H.C.

Congas

Anna *mf*

Han var en krig - er, han var en hjem - løs, han var en stats - løs.

Esther *mf*

Han var en krig - er, han var en hjem - løs, han var en stats - løs.

kor *mf*

Han var en krig - er, han var en hjem - løs, han var en stats - løs.

Vln. A

Vln+div

Vln. 1 arco *mf*

Vln. 2 arco *mf*

Vla. arco *mf*

Vc. *mf*

Cb.

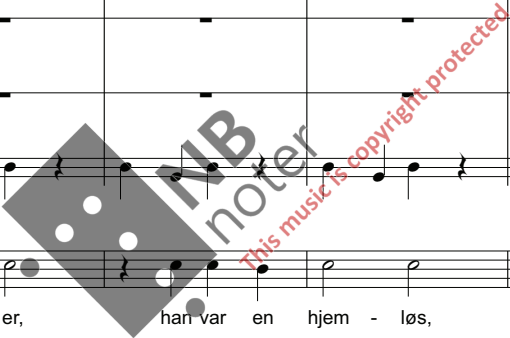



Fl.

Cl.

Gtr.

tar

synth

Accord.

Bongos

Gro.

H.C.

Congas

Anna

Esther

kor

Vln. A

Vln+div

Vln. 1

Vln. 2

Vla.

Vc.

Cb.

vi møt - er hjem - lø-se nå, vi mø - ter stats - lø-se nå, de sam - me stjer - ne-ne som

vi møt - er hjem - lø-se nå, vi møt - er stats - lø-se nå, de sam - me stjer - ne-ne som

vi møt - er hjem - lø-se nå, vi møt - er stats - lø-se nå, de sam - me stjer - ne-ne som

*MB noter*  
*this music is copyright protected*

Fl.

Cl.

Gtr.

tar

synth

Accord.

Bongos

Gro.

H.C.

Congas

Anna 

Esther

kor

Vln. A

Vln+div

Vln. 1

Vln. 2

Vla.

Vc.

Cb.

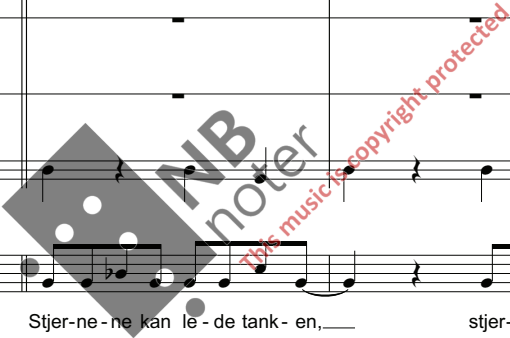

58 203

Fl. *f*

Cl. *f*

Gtr. *f*

tar

synth *f*

Accord. *f*

Bongos *f*

Gro. *mf*

H.C.

Congas *f*

Anna  
stjer-ne-ne kan le-de på din vei.

Esther  
før - er deg frem.

kor

Vln. A *f*

Vln+div *f*

Vln. 1 *f* arco

Vln. 2 *f* arco

Vla. *f* arco

Vc. *f*

Cb. *f*

63

Fl.

Cl.

Gtr.

tar

synth

Accord.

Bongos

Gro.

H.C.

Congas

Anna

Esther

kor

Vln. A

Vln+div

Vln. 1

Vln. 2

Vla.

Vc.

Cb.

This music is copyright protected



68 205

Fl.

Cl.

Gtr.

tar

synth

Accord.

Bongos

Gro.

H.C.

Congas

Anna

Esther

kor

Vln. A

Vln+div

Vln. 1

Vln. 2

Vla.

Vc.

Cb.

This music is copyright protected

73

Fl.

Cl.

Gtr.

tar

synth

Accord.

Bongos

Gro.

H.C.

Congas

Anna

Esther

kor

Vln. A

Vln+div

Vln. 1

Vln. 2

Vla.

Vc.

Cb.

This music is copyright protected

# Lux del 17

Fra Olavssekvensen Lux illuxit

Bertil Palmar Johansen

$\text{♩} = 60$  (solo: Den unge pilegrim - "Anna".)

solo

Vokal 1

*mp*

Lux il - lux - it læ - ta bun - da, Lux il - lu stris, lux iu - cun - da

Vokal 2

*mp*

Lux il - lux - it læ - ta, Lux il - lu - -

Vokal 3

*mp*

Lux il - lux - it læ - ta bun - da, Lux il - lu - stris,

6

vok.1

Lux dig - na præ - co - ni - o. In sol - lem - ne gau - di - um,

vok.2

stris, Lux dig - na, co - ni - o. In sol - lem - ne gau - di,

vok.3

Lux dig - na præ co - ni - o. In sol -

10

vok.1  
pro-rum pat fi-de - li - um sin - ce - ra de - vo - ti - o.

vok.2  
pro-rum pat fi-de - li - um sin - ce - ra vo - ti - o. *mp* Glo - ri - o-sus ho-di-

vok.3  
lem - ne gau-di-um, ra de vo - ti - o. *mp* Glo - ri -

14

vok.1  
*mf* Chris-ti mar - tyr glo - ri - æ, Chris -

vok.2  
*mf* e, o-sus-ho-di - e, Chris - ti mar - tyr glo-ri-æ, Chris -

vok.3  
*mf* o-sus-ho-di-e, Chris-ti mar - tyr glo - ri - æ sub - li,

18

vok.1  
- ti, sub - li - ma - tus so - li - o

vok.2  
ti, sub - li - ma - tus so - li - o.

vok.3  
sub - li - ma - tus so - li - o

22

*mp*

vok.1  
Rex et mar-tyr tri-um-pha-lis tu-tor no-ster spe-ci - a - lis, tu - a pro-les

*mp*

vok.2  
Rex et mar-tyr tri-um-pha-lis tu-tor no-ster spe-ci - a - lis, tu - a

*mp*

vok.3  
Rex et mar-tyr tri-um-pha-lis tu-tor no-ster spe-ci - a - lis,

27

solo Den unge pilegrim - "Anna". *mf*

Lux

vok.1  
spi-ri ta - lis sit ab hu-ius mun-di ma-lis, li - be - ra.

*p*

vok.2  
pro - les, sit ab hu-ius mun-di ma-lis, Te tu - en - te

*p*

vok.3  
spi-ri-ta - lis sit ab hu-ius mun-di ma-lis, Te tu - en - te li - be - ra.

32

solo  
il - lu - xit læ-ta-bun-da, lux il - lu - stris, lux iu - cun -

*p*

vok.1  
Te tu - en - te li - be - ra. Te tu - en - te li - be -

vok.2  
li - be - ra. Te tu - en - te li - be - ra.

vok.3  
Te tu - en - te li - be - ra. Te tu -

36

solo  
da, quæ dig - na præ - co-ni - o. In\_\_\_ so-lem- ne\_\_\_ gau - di - um,

vok.1  
-ra. Te tu - en\_ te li be - ra, li be -

vok.2  
Te tu - en - te li - be - ra, li be -

vok.3  
en - te li - be - ra. Te tu - en\_ te li - be\_ ra.

40

solo  
gau - di - um, *mf* pro-rum-pat fi - de - li - um

vok.1  
-ra. Lux il - lux it, Lux il - lux\_ it, lux il - lux - it,\_\_\_

vok.2  
-ra. *mf* Lux il - lux - it, lux il - lux - it, lux il - lux - it,

vok.3  
*mf* Lux il - lux - it, # lux il - lux - it, lux # li - lux - it,

44

solo  
sin - ce - ra de - vo - ti - o. Lux il-lux - it. *mf*

vok.1  
lux il - lux - it,\_\_\_ lux il - lux - it, Lux il-lux - it. *mf* Mi - se - re-re,

vok.2  
lux il - lux - it, lux il - lux\_ it, Lux il-lux - it. *mf* Mi - se - re-re,

vok.3  
lux il - lux - it, lux il - lux - it, Lux il-lux - it. *mf* Mi - se - re-re,

♩ = 96

49

solo

vok.1

*p*

mi - se re-re, mi - se -re-re, mi - se -re-re, mi - se-re-re no-bis, mi - se-re-re,

vok.2

*p*

mi - se-re-re, mi - se - re-re, mi - se - re-re, mi - se-re-re no-bis, mi - se-re-re,

vok.3

*p*

mi - se-re-re, mi - se - re-re, mi - se - re-re, mi - se-re-re no-bis, mi - se-re-re,

54

vok.1

mi - se - re - re, mi - se-re-re no-bis, mi se - re - re, mi - se - re - re,

vok.2

mi - se - re - re, mi - se-re-re no-bis, mi - se - re - re, mi-se - re - re,

vok.3

mi - se - re - re, mi - se - re - re, mi - se-re-re no-bis, mi - se - re - re,

58

vok.1

mi - se-re-re no - bis, mi - se - re - re mis - se-re-re no - bis,

vok.2

mi - se-re-re no - bis, mi - se - re - re, mi - se - re - re, mi -

vok.3

mi - se-re-re no - bis, mi - se - re - re, mi - se - re - re,

61 *f*

vok.1  
mi - - se - re - re, mi - se - re - re no - bis, se -

vok.2  
*f*  
- se - re - re, mi - - se - re - re no - bis, mi - se - re - re no - bis,

vok.3  
*f*  
mi - - se - re - re no - bis, mi - - - se - re - re,

63 *rit.*  $\text{♩} = 60$

vok.1  
re - re no - bis mi - se - re - re no - bis, Mi - se -

vok.2  
no - bis, mi - se - re - re no - bis, mi - se - re - re, Mi - se -

vok.3  
mi - se - re - re no - bis, mi - se - re - re, Mi - se -

66 *mp*

vok.1  
re - re no bis. A - - - - - men.

vok.2  
*mp*  
re - re no - bis. A - - - - - men.

vok.3  
*mp*  
re - re no - bis. A - - - - - men.





Fl.

Cl.

Gtr.

tar

synth

Accord.

Cab.

H.C.

H.C.

Congas

A/E

Abd

Vln. A

Vln. +div

Vln. 1

Vln. 2

Vla.

Vc.

Cb.

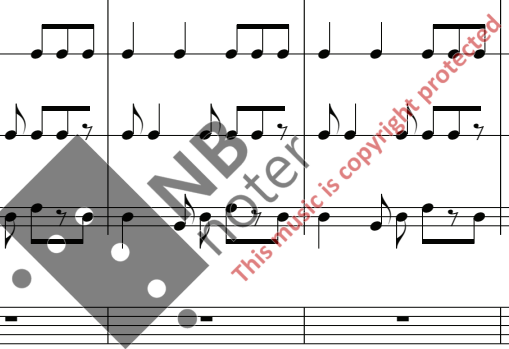

Fl.

Cl.

Gtr.

tar

synth

Accord.

Cab.

H.C.

H.C.

Congas

Esther:  
A/E   
Ber vå-re bøn-ner, Hel - li-ge brøn-ner, sol ov-er fjell gjør som-mer-dag-en het, kil - der og bre - er, kirk - er, mos-ke - er,

Abd

Vln. A

Vln. +div

Vln. 1

Vln. 2

Vla.

Vc.

Cb.



Fl.

Cl.

Gtr.

tar

synth

Accord.

Cab.

H.C.

H.C.

Congas

A/E   
vand - rer vi i takk-nem - lig - het.

Abd

Vln. A   
pizz  
f pizz

Vln. +div

Vln. 1

Vln. 2

Vla.

Vc.

Cb.

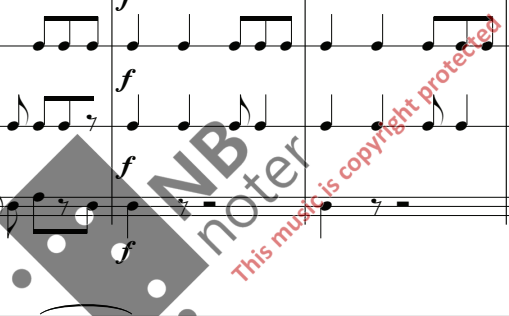

Fl. 

Cl. 

Gtr. 

tar 

synth 

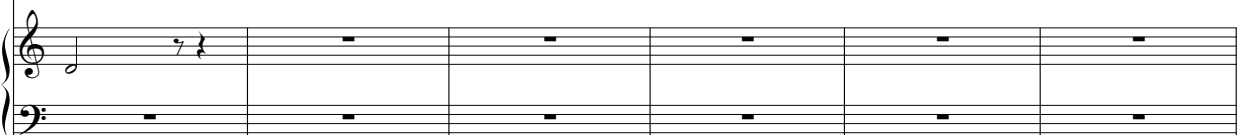
Accord. 

Cab. 

H.C. 

H.C. 

Congas 

A/E 

Abd 

Vln. A 

Vln. +div 

Vln. 1 

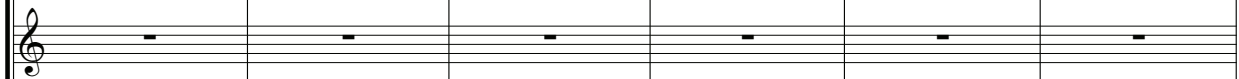
Vln. 2 

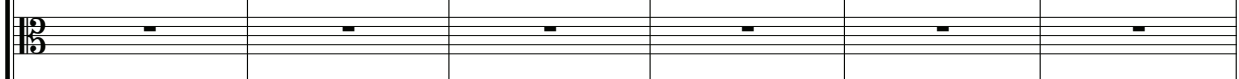
Vla. 

Vc. 

Cb. 



Fl.

Cl.

Gtr.

tar

synth

Accord.

Cab.

H.C.

H.C.

Congas

A/E

Abd

Vln. A

Vln. +div

Vln. 1

Vln. 2

Vla.

Vc.

Cb.

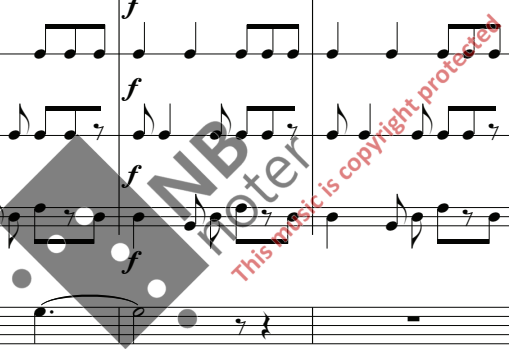

Fl.

Cl.

Gtr.

tar

synth

Accord.

Cab.

H.C.

H.C.

Congas

A/E

Abd   
 Abdullah:  
 Jeg ser gren-en på en pal-me, fra den dryp-per blodet av,  
 arco

Vln. A

Vln. +div

Vln. 1

Vln. 2

Vla.

Vc.

Cb.

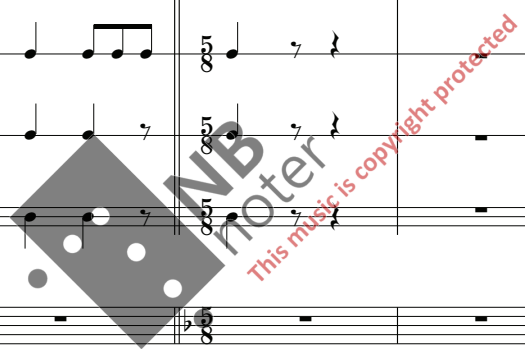

Fl.

Cl.

Gtr.

tar

synth

Accord.

Cab.

H.C.

H.C.

Congas

A/E

Abd

Vln. A

Vln. +div

Vln. 1

Vln. 2

Vla.

Vc.

Cb.

og en bar-bent mor som flykt er \_\_\_ i fra hus-et der hun bor. Lyn som fler rer, \_\_\_drønn av tord-en, se en skole

**NB** noter  
This music is copyright protected



Fl.

Cl.

Gtr.

tar

synth

Accord.

Cab.

H.C.

H.C.

Congas

A/E

Abd   
 fal - ler sam men, ba-re blod og mur - stein.

Vln. A

Vln. +div

Vln. 1

Vln. 2

Vla.

Vc.

Cb.



Fl. *f*

Cl. *f*

Gtr. *f*

tar *f*

synth *f*

Accord. *f*

Cab.

H.C.

H.C.

Congas

A/E

Abd Abraham danser

Vln. A *f*

Vln. +div *f*

Vln. 1 *f* pizz

Vln. 2 *f* pizz

Vla. *f* pizz

Vc. *f* pizz

Cb. *f*

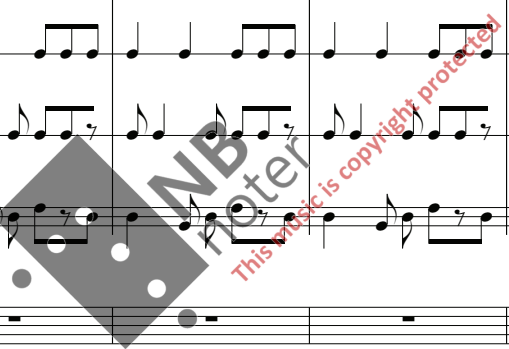

Fl.

Cl.

Gtr.

tar

synth

Accord.

Cab.

H.C.

H.C.

Congas

A/E

Abd

Vln. A

Vln. +div

Vln. 1

Vln. 2

Vla.

Vc.

Cb.

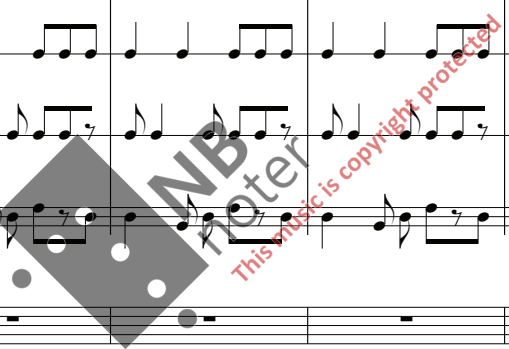

Fl.

Cl.

Gtr.

tar

synth

Accord.

Cab.

H.C.

H.C.

Congas

A/E

Abd

Vln. A

Vln. +div

Vln. 1

Vln. 2

Vla.

Vc.

Cb.

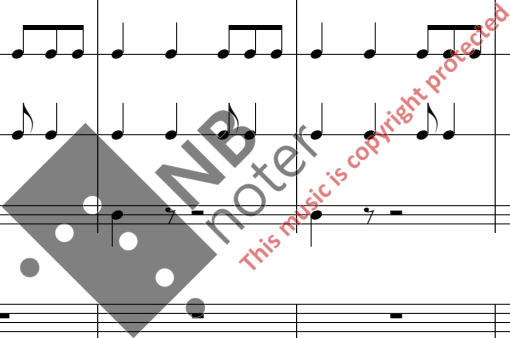

Fl.

Cl.

Gtr.

tar

synth

Accord.

Cab.

H.C.

H.C.

Congas

A/E   
 Anna:  
 Jeg så en gutt, han bar le-ke-tøy - et sitt i et bel te.

Abd

Vln. A

Vln. +div

Vln. 1   
arco

Vln. 2   
arco

Vla.   
arco

Vc.

Cb.

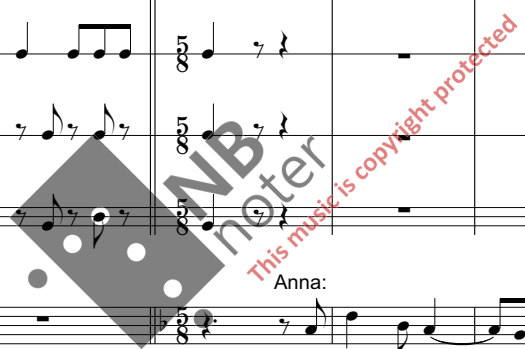

Fl.

Cl.

Gtr.

tar

synth

Accord.

Cab.

H.C.

H.C.

Congas

A/E

Abd

Vln. A

Vln. +div

Vln. 1

Vln. 2

Vla.

Vc.

Cb.

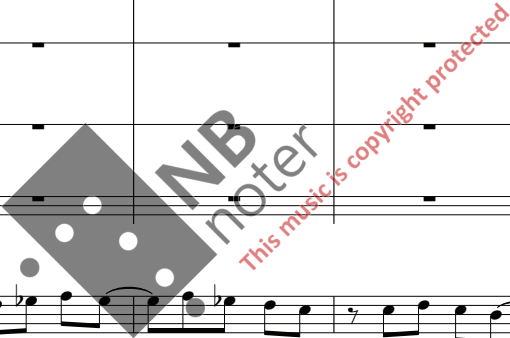

Fl.

Cl.

Gtr.

tar

synth

Accord. ad lib. impro.

Cab.

H.C.

H.C.

Congas

A/E i sitt bel te?\_\_ Gut-ten står og smi - ler.

Abd

Vln. A

Vln. +div

Vln. 1

Vln. 2

Vla.

Vc.

Cb.

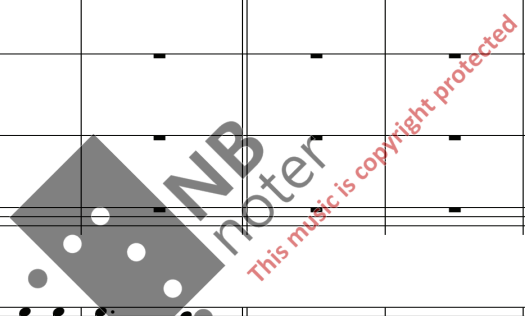

# Ung jasmin del 19

Bertil Palmar Johansen  
Terje Nordby

♩ = 60

Clarinet in B $\flat$

Bongos

Congas

♩ = 60

Kor 1  
Mel-lom hav og ørk-en, mur - er, tårn og

Kor 2  
Mel-lom hav og ørk-en,

Kor 3  
Mel-lom hav og ørk-en, mur - er, tårn og

4  
Cl.

Bongos

Congas

K 1  
gat - er bloms - trer nå jas -

K 2  
bloms - trer nå jas -

K 3  
gat - er bloms - tre nå,

**NB** noter  
This music is copyright protected



6  
Cl.

Bongos

Congas

K 1

min - en. sprer sin duft om

K 2

min - en. sprer sin duft om

K 3

sprer sin duft om

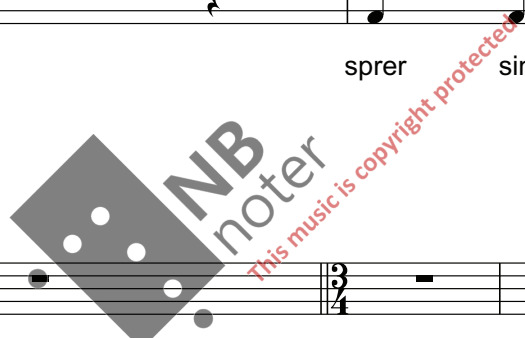

8  
Cl.

Bongos

Congas

K 1

nat - ten, Vår, det er vår i mitt land, mitt

K 2

nat - ten, Vår, det er vår.

K 3

nat - ten. Vår, det er vår i mitt land, mitt

230 13  
Cl.

Bongos  
Congas

K 1  
land. Kref - ter skjult i

K 2  
Kref - ter skjult i

K 3  
land. Kref - ter skjult i

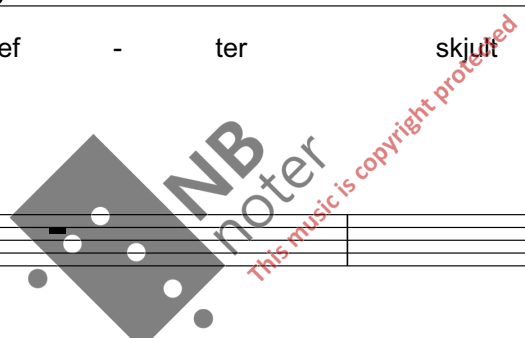

15  
Cl.

Bongos  
Congas

K 1  
mørk - et, Ung og hvit jas -

K 2  
mørk - et, Ung og hvit jas -

K 3  
mørk - et, Ung og hvit jas -

Cl.

Bongos

Congas

K 1

K 2

K 3

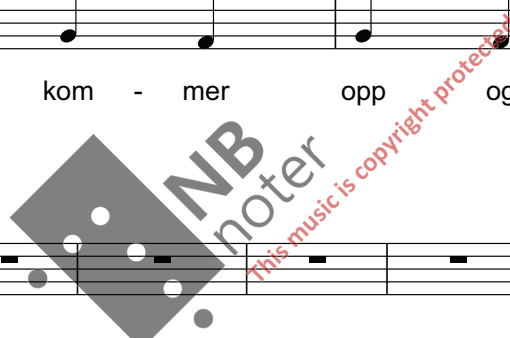

Cl.

Bongos

Congas

K 1

K 2

K 3

Cl.

Bongos

Congas

K 1

Hør, den sprer seg med vind-en, med fri - hets-vind-en til al - le som søk-er den.

K 2

Hør, den sprer seg med vind-en, med fri - hets vind-en til al - le som søk-er den.

K 3

Hør, den sprer seg med vind-en, med fri - hets-vind-en til al - le som søk-er den.

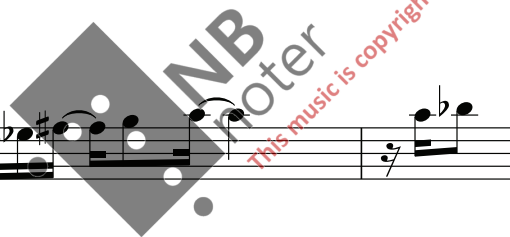

Cl.

Bongos

Congas

K 1

K 2

K 3

36 233

Cl.

Bongos

Congas

K 1

K 2

K 3

38

Cl.

Bongos

Congas

K 1

K 2

K 3

Fri - het er en hvi t jas - min som

Fri - het er en hvi t jas - min som

Fri - het er en hvi t jas - min som

234

43

Cl.

Bongos

Congas

K 1 duft - es inn av et barn og sprer seg med vind - en, med

K 2 duft - es inn av et barn og sprer seg med vind - en, med

K 3 duft - es inn av et barn og sprer seg med vind - en, med



48

Cl.

Bongos

Congas

K 1 fri - hets vind - en til he - le verd - en, ja he - le verd - en.

K 2 fri - hets - vind - en til he - le verd - en, ja he - le verd - en.

K 3 fri - hets - vind - en til he - le verd - en, ja he - le verd - en.

# Vi har forandret våre mål del 20

235

Bertil Palmar Johansen  
Terje Nordby

$\text{♩} = 104$

The musical score is arranged in a standard orchestral format with the following parts from top to bottom:

- Flute
- Clarinet in B $\flat$
- Guitar (*mp*)
- Tar (*mp*)
- Synth (*mp*) with marimba accompaniment
- Accordion
- Cabasa
- Xylophone (*mp*)
- Marimba (*mp*)
- Anna
- Esther
- Abdullah (with lyrics: *Abdullah: Vi vil - le nå et hel - lig mål som gav oss ro,*)
- Violin A (*mf pizz*)
- Viol+div (*mf pizz*)
- Violin 1 (*mf pizz*)
- Violin 2 (*mf pizz*)
- Viola (*pizz*)
- Violoncello (*pizz mf*)
- Contrabass (*mf*)

A large watermark 'NB noter' is visible across the center of the page, along with the text 'This music is copyright protected'.

Fl. *mp*

Cl.

Gr.

tar

synth

Accord.

Cab.

Xyl.

Mar.

Anna

Esther: Men vi ser

Abd. en hel - lig fred i vå - re sinn.

Vln. A

Vln.+div

Vln. 1

Vln. 2

Vla.

Vc.

Cb.





Fl.

Cl.

Gr.

tar

synth

Accord.

Cab.

Xyl.

Mar.

Anna

Esther   
 verd - en, ja, vi ser verd - en mens vi går, og verd - en den for-andr - er

Abd.

Vln. A

Vln.+div

Vln. 1

Vln. 2

Vla.

Vc.

Cb.



Fl. *mf*

Cl. *mf*

Gr. *mf*

tar *mf*

synth *mf*

Accord. *mf*

Cab. *mf*

Xyl. *mf*

Mar. *mf*

Anna *mf* +kor

Esther *mf* +kor

Abd. *mf* +kor

Vln. A *mf*

Vln.+div *mf*

Vln. 1 *mf*

Vln. 2 *mf*

Vla. *mf*

Vc. *mf*

Cb. *mf*

Pigg - tråd og po - li - tikk, små føt - ter på ge - ledd,  
 vå - re mål. Pigg - tråd og po - li - tikk, små føt - ter på ge - ledd,  
 Pigg - tråd og po - li - tikk, små føt - ter på ge - ledd,

Fl.

Cl.

Gr.

tar

synth

Accord.

Cab.

Xyl.

Mar.

Anna   
bomb - er i bloms - ter bedd, stil - le og gif - tig vann, grå - di - ge,

Esther   
bomb - er i bloms - ter bedd, stil - le og gif - tig vann, grå - di - ge,

Abd.   
bomb - er i bloms - ter bedd, stil - le og gif - tig vann, grå - di - ge,

Vln. A

Vln.+div

Vln. 1

Vln. 2

Vla.

Vc.

Cb.



This musical score page contains measures 240 through 244. It features a variety of instruments and vocal parts. The woodwinds include Flute (Fl.), Clarinet (Cl.), and Bassoon (Mar.). The strings consist of Violin A (Vln. A), Violin B (Vln. 2), Violin C (Vln. 1), Violin D (Vln.+div), Viola (Vla.), Violoncello (Vc.), and Contrabass (Cb.). Percussion includes Tambourine (Tgr.), Xylophone (Xyl.), and Maracas (Mar.). The vocal parts are for Anna, Esther, and Abd. The score includes dynamic markings such as *mf* and *f*. The key signature has one flat, and the time signature changes from 4/4 to 3/8, then back to 4/4, and finally to 5/4. A large watermark for 'NB noter' is overlaid on the page.

Fl. *mf*

Cl. *mf*

Tgr. *mf*

synth *mf*

Accord.

Cab.

Xyl. *mf*

Mar. *mf*

Anna  
sti - ve blick, fat - tig - folk i pa - nikk Vi har for-andr-et vå-re mål!

Esther  
sti - ve blick, fat - tig - folk i pa - nikk Vi har for-andr-et vå-re mål!

Abd.  
sti - ve blick, fat - tig - folk i pa - nikk Vi har for-andr-et vå-re mål!

Vln. A *mf*

Vln.+div *mf*

Vln. 1 *mf*

Vln. 2 *mf*

Vla. *mf*

Vc. *mf*

Cb. *mf*

Fl. *mf*

Cl. *mf*

Gr. tar

synth

Accord. *mf*

Cab.

Xyl.

Mar.

+kor *mf*  
Anna  
Vi vil - le fred, en hel - lig fred i vå - re

+kor *mf*  
Esther  
Vi vil - le fred, en hel - lig fred i vå - re

+kor *mf*  
Abd.  
Vi vil - le fred, en hel - lig fred i vå - re

Vln. A

Vln.+div

Vln. 1

Vln. 2

Vla.

Vc.

Cb.



Fl.

Cl.

Gtr.

tar

synth

Accord.

Cab.

Xyl.

Mar.

Anna

Esther

Abd.

Vln. A

Vln.+div

Vln. 1

Vln. 2

Vla.

Vc.

Cb.

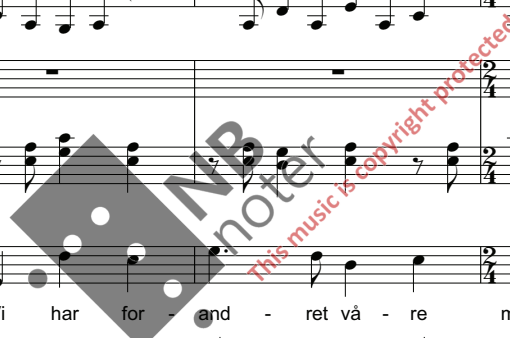

# Flor del Mirto del 21

Bertil Palmar Johansen  
Terje Nordby

$\text{♩} = 140$

The musical score is arranged in a system of staves. The instruments and their parts are as follows:

- Flute:** Resting throughout the piece.
- Clarinet in B $\flat$ :** Melodic line with a *mf* dynamic.
- Guitar:** Melodic line with a *mf* dynamic.
- Tar:** Resting throughout the piece.
- Synth:** Melodic line with a *mf* dynamic.
- Accordion:** Melodic line with a *mf* dynamic.
- Bass Drum:** Rhythmic pattern with a *mf* dynamic.
- Bongos:** Rhythmic pattern with a *mf* dynamic.
- Handclap:** Rhythmic pattern with a *mf* dynamic.
- Tambourine:** Resting throughout the piece.
- Anna:** Resting throughout the piece.
- Esther:** Resting throughout the piece.
- Abdullah:** Resting throughout the piece.
- Violin A:** Melodic line with a *mf* *pizz* dynamic.
- Viol. +div:** Harmonic accompaniment with a *mf* *pizz* dynamic.
- Violin 1:** Melodic line with a *mf* *pizz* dynamic.
- Violin 2:** Harmonic accompaniment with a *mf* *pizz* dynamic.
- Viola:** Harmonic accompaniment with a *mf* *pizz* dynamic.
- Violoncello:** Resting throughout the piece.
- Contrabass:** Resting throughout the piece.

A large watermark for "NB-noter" is visible across the middle of the score, with the text "this music is copyright protected" written diagonally.

This musical score is for a chamber ensemble and orchestra. The instruments listed on the left are:

- Fl. (Flute)
- Cl. (Clarinet)
- Gtr. (Guitar)
- tar. (Tambourine)
- synth (Synthesizer)
- Accord. (Accordion)
- B. D. (Bongos)
- Bongos
- H.C. (Hand Cymbal)
- Tamb. (Tambourine)
- Anna (Vocalist)
- Esther (Vocalist)
- Abd. (Vocalist)
- Vln. A (Violin A)
- Vln. + div (Violin + Divisi)
- Vln. 1 (Violin 1)
- Vln. 2 (Violin 2)
- Vla. (Viola)
- Vc. (Violoncello)
- Cb. (Contrabasso)

The score is divided into three measures. The first two measures show the initial melodic and harmonic development for the woodwinds, guitar, synth, and accordion. The third measure, marked with a double bar line and a repeat sign, features a dynamic shift to *f* (forte) and includes a section for the strings, with the Violin 1 part marked *arco* (arco). The percussion parts (Bongos, Hand Cymbal, Tambourine) continue their rhythmic patterns throughout the piece.

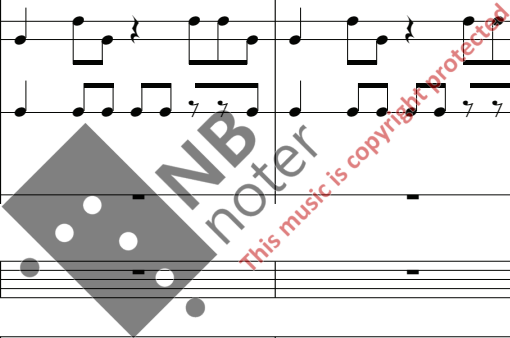



Fl. *mp*

Cl.

Gtr.

tar.

synth *mp*

Accord.

B. D. *mp*

Bongos *mp*

H.C. *mp*

Tamb. *mp*

Anna

Esther

(Om du els-ker meg,  
Si tu me a - mas,

Abd.

Vln. A *mp*

Vln. +div *mp*

Vln. 1

Vln. 2 *arco mp*

Vla. *mp*

Vc. *mp*

Cb. *mp*

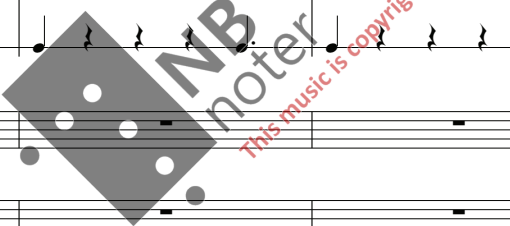

Fl.

Cl.

Gtr.

tar.

synth

Accord.

B. D.

Bongos

H.C.

Tamb.

Anna

Esther

Abd.

Vln. A

Vln. +div

Vln. 1

Vln. 2

Vla.

Vc.

Cb.

kom og ta meg i din favn , Er - te-bloms-ten den be tyr\_ at jeg els-ker deg. Jor-den den er god,  
 ven y\_\_ a-bra-za- me, flor del mir - to sign-i - fi - ca que te a - mo. La ti - er-ra nues-tra.

*Watermark: NB noter. This music is copyright protected.*

Fl. *mf*

Cl. *mf*

Gtr.

tar.

synth *mf* *plystrelyd*

Accord. *mf*

B. D. *mf*

Bongos *mf*

H.C.

Tamb. *mf*

Anna

Esther

Gud ser ned på oss i nåde, Mar-ga-rit-ter de er som - en sol i mitt liv.)  
 Dios mi - ra ha - cia a - ba - jo, Mar-ga-rit - as son co - mo \_ sol en mi - vi - da.

Abd.

Vln. A *arco* *mf*

Vln. +div *mf*

Vln. 1 *mf*

Vln. 2 *mf* *arco*

Vla. *mf*

Vc. *mf*

Cb. *mf*



Fl.

Cl.

Gtr.

tar.

synth

Accord.

B. D.

Bongos

H.C.

Tamb.

Anna

Esther

Abd.

Vln. A

Vln. +div

Vln. 1

Vln. 2

Vla.

Vc.

Cb.

Fl. *mf*

Cl.

Gtr. *mf*

tar.

synth *mf*

Accord. *mf*

B. D. *mf*

Bongos *mf*

H.C. *mf*

Tamb. *mf*

Anna

Esther

Abd. *turteldue duekylling*  
 Tor - to - la, pa - lo - mi - no,

Vln. A *mf pizz*

Vln. +div *mf*

Vln. 1 *mf pizz*

Vln. 2 *mf pizz*

Vla. *mf*

Vc. *mf*

Cb. *mf*

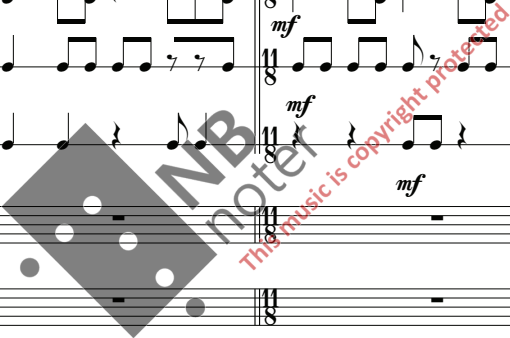

Fl.

Cl.

Gtr.

tar.

synth

Accord.

B. D.

Bongos

H.C.

Tamb.

Anna

Esther

Abd.

Vln. A

Vln. +div

Vln. 1

Vln. 2

Vla.

Vc.

Cb.

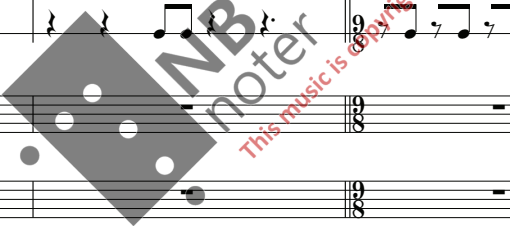

arco

arco mp

arco mp

mp

mp

mp

Fl. *mf*

Cl.

Gtr. *mf*

tar.

synth *mf*

Accord. *mf*

B. D. *mf*

Bongos *mf*

H.C. *mf*

Tamb. *mf*

Anna *mf* turteldue duekylling

Tor - to - la, pa - lo - mi - no,

Esther *mf* turteldue duekylling

Tor - to - la, pa - lo - mi - no,

Abd. *mf* pe-on-og a-ma-ryl-lis, val-mu-e og floks,

Vln. A *mf* pizz

Vln. +div *mf* pizz

Vln. 1 *mf*

Vln. 2 *mf* pizz

Vla. *mf*

Vc. *mf*

Cb. *mf*

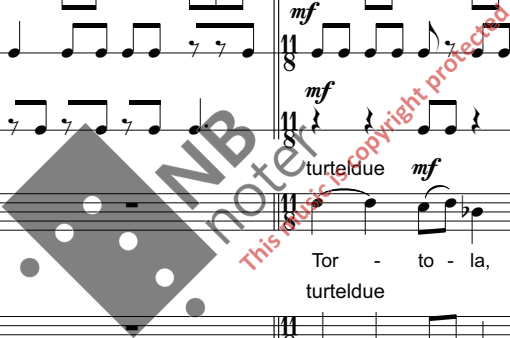

Fl. *f*

Cl. *f*

Gtr. *f*

tar. *f*

synth *f*

Accord. *f*

B. D. *f*

Bongos *f*

H.C. *f*

Tamb. *f*

Anna  
 svale kanarifugl  
 go - lon - dri - na, ka - na - ri - o. kor synger med her.

Esther  
 svale kanarifugl  
 go - lon - dri - na, ka - na - ri - o. *f* La li la li lå, La li la li lå, -

Abd.

Vln. A *f*

Vln. +div *f*

Vln. 1 *f*

Vln. 2 *f*

Vla. *f*

Vc. *f*

Cb. *f*





Fl.

Cl.

Gtr.

tar.

synth

Accord.

B. D.

Bongos

H.C.

Tamb.

Anna

Esther

Abd.

Vln. A

Vln. +div

Vln. 1

Vln. 2

Vla.

Vc.

Cb.



Fl.

Cl.

Gtr.

tar.

synth

Accord.

B. D.

Bongos

H.C.

Tamb.

Anna

Esther

Abd.

Vln. A

Vln. +div

Vln. 1

Vln. 2

Vla.

Vc.

Cb.

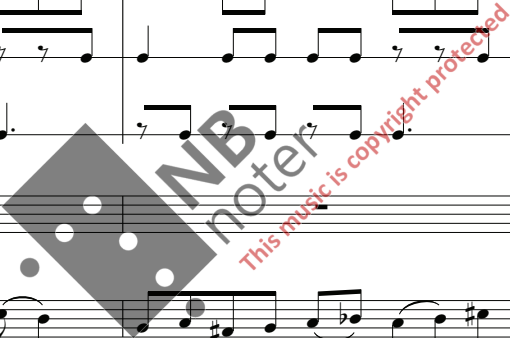

# Vi må fremover del 22

255

Bertil Palmar Johansen  
Terje Nordby

$\text{♩} = 80$

Flute *mf*

Clarinet in B $\flat$  *mf*

Guitar *mf*

Tar

el.piano *mf*

Synth *mf*

Accordion *mf*

Anna

Esther

Abdullah

Violin A *mf*

Viol+div *mf*

Violin 1 *mf*

Violin 2 *mf*

Viola *mf*

Violoncello *mf*

Contrabass *mf*

Fl.

Cl.

*mp*

Gtr.

tar

synth

Accord.

Anna

Esther

Abd.

Vln. A

Vln+div

Vln. 1

Vln. 2

Vla.

Vc.

Cb.

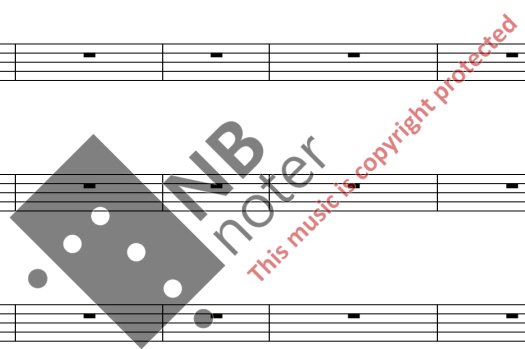

Fl.

Cl.

Gtr. *mp*

tar

synth *p*   
strings *mp*

Accord. *mf*

Anna   
Hva slags makt dyrk-er du med din sang og bønn i dis-se en - som - me rom? La

Esther   
La

Abd.

Vln. A *pp*   
*mp*

Vln+div *pp*   
*mp*

Vln. 1 *pp*   
*mp*

Vln. 2 *pp*   
*mp*

Vla. *pp*   
*mp*

Vc. *pp*   
*mf* pizz

Cb. *pp*   
*mf*



Fl.

Cl.

Gtr.

tar

synth

Accord.

Anna   
vær La vær å tro at Han

Esther   
vær. å tro at Gud er stengt inn - e med deg her! La vær.

Abd.   
vær. La vær.

Vln. A

Vln+div

Vln. 1

Vln. 2

Vla.

Vc.

Cb.



Fl. *mp*

Cl. *mp*

Gtr. *mf*

tar

synth *f* *el. piano mp*

Accord.

Anna  
 \_ er der sei-er-en er.

Esther

Abd.  
 Han er der en slit-er bryt-er stein. Han er der \_\_\_\_ en bon-de pløy-er jord. Han er sam -

Vln. A *f* *mp*

Vln+div *f* *mp*

Vln. 1 *f* *mp*

Vln. 2 *f* *mp*

Vla. *f* *mp*

Vc. *f* *mp arco*

Cb. *f* *mp arco*

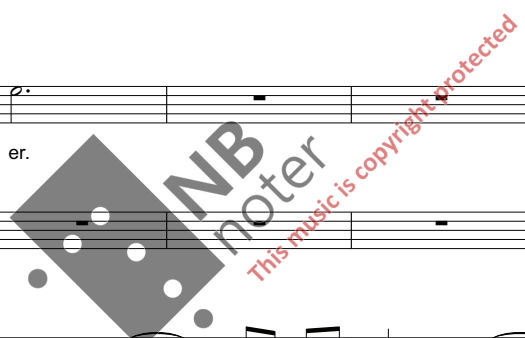

Fl.

Cl.

Gtr.

tar

synth

Accord.

Anna 

Esther

Abd. 

Vln. A

Vln+div

Vln. 1

Vln. 2

Vla.

Vc.

Cb.

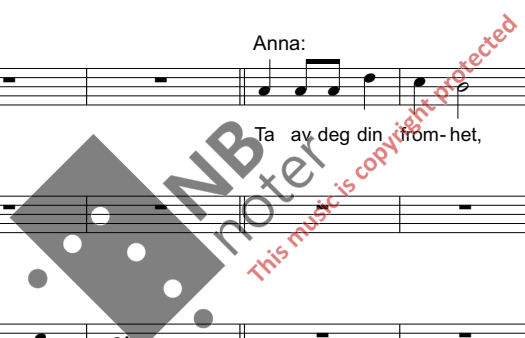





Fl. *mf*

Cl. *mf*

Gtr.

tar

synth *mf*

Accord. *mf*

Anna *mf* +kor  
 møt Ham og vær hos Ham i svet-te og strev. Se å kom deg ut, vi må

Esther *mf*  
 - le-fred, møt Ham og vær hos Ham i svet-te og strev. Se å kom deg ut, vi må

Abd. *mf*  
 møt Ham og vær hos Ham i svet-te og strev. Se å kom deg ut, vi må

Vln. A *mf*

Vln+div *mf*

Vln. 1 *mf*

Vln. 2 *mf*

Vla. *mf*

Vc. *mf*

Cb. *mf*



Fl.

Cl.

Gtr.

tar

synth

Accord.

Anna  
frem - ov - er. Ta av deg ditt hov-mot og kom ned, ned hit på jor - da til

Esther  
frem - ov - er. Ta av deg ditt hov-mot og kom ned, ned hit på jor - da til

Abd.  
frem - ov - er. Ta av deg ditt hov-mot og kom ned, ned hit på jor - da til

Vln. A

Vln+div

Vln. 1

Vln. 2

Vla.

Vc.

Cb.

Fl.

Cl.

Gtr.

tar

synth

Accord.

Anna

Gud. ned hit på jor - da til Gud.

Esther

Gud. ned hit på jor - da til Gud.

Abd.

Gud. ned hit på jor - da til Gud.

Vln. A

Vln+div

Vln. 1

Vln. 2

Vla.

Vc.

Cb.

Dette resiteres mellom del 22 og 23  
3 "Fri oss i fra historiens garn,  
la stjernene lyse på Abrahams barn"

2 "Lær oss å se hvor føttene trår"

1 "Lær av hver udåd vi alle begår"

NB noter  
This music is copyright-protected

# Abrahams barn - Sluttsalme del 23

Bertil Palmar Johansen  
Terje Nordby

♩ = 96

Flute *mf*

Clarinet in B $\flat$  *mp*

Synth *mf*

Accordion *mf*

Vibraphone

kor+Anna  
A - bra-ham lyt - tet til Gud und-er stjer-ne-ne, Brøt opp og vand - ret på jord-en som en

kor+Esther  
A - bra-ham lyt - tet til Gud und-er stjer-ne-ne, Brøt opp og vand - ret på jord-en som en

Abdullah  
A - bra-ham lyt - tet til Gud und-er stjer-ne-ne, Brøt opp og vand - ret på jord-en som en

Violin A *mf*

Viol+div *mf*

Violin 1 *mf*

Violin 2 *mf*

Viola *mf*

Violoncello *mf*

Contrabass *mf*

8

Fl.

Cl.

synth

Accord.

Vib.

kor+A

kor+E

Abd.

Vln. A

Vln.+div

Vln. 1

Vln. 2

Vla.

Vc.

Cb.

flykt - ning. Bud - bring-er, se - er, far til de rast - lø - se man - ge, A bra-hams

flykt - ning. Bud - bring-er, se - er, far til de rast - lø - se man - ge, A - bra-hams

flykt - ning. Bud - bring-er, se - er, far til de rast - lø - se man - ge, A bra-hams

*Watermark: NBNB noter.com This music is copyright protected*

Detailed description of the musical score: The score is for page 266 and consists of 12 staves. The instruments and parts are: Flute (Fl.), Clarinet (Cl.), Synth, Accordion (Accord.), Vibraphone (Vib.), Soprano (kor+A), Alto (kor+E), Bass (Abd.), Violin A (Vln. A), Violin/Divisi (Vln.+div), Violin 1 (Vln. 1), Violin 2 (Vln. 2), Viola (Vla.), Violoncello (Vc.), and Contrabass (Cb.). The key signature has one flat (B-flat). The tempo is marked with a common time signature (C). The score includes a large watermark 'NBNB noter.com' and a red diagonal line with the text 'This music is copyright protected'. The lyrics for the vocal parts are: 'flykt - ning. Bud - bring-er, se - er, far til de rast - lø - se man - ge, A bra-hams' for the Soprano, Alto, and Bass parts.

15

Fl.

Cl.

synth

Accord.

Vib.

kor+A

kor+E

Abd.

Vln. A

Vln.+div

Vln. 1

Vln. 2

Vla.

Vc.

Cb.



22

Fl.

Cl.

synth

Accord.

Vib.

kor+A

kor+E

Abd.

Vln. A

Vln.+div

Vln. 1

Vln. 2

Vla.

Vc.

Cb.

sø-ker vi for-son- ing, ser he-le liv - et spen - ne fra jub - el til sorg - er, tår - er og

sø-ker vi for-son- ing, ser he-le liv - et spen - ne fra jub - el til sorg - er, tår - re og

sø-ker vi for-son- ing, ser he-le liv - et spen - ne fra jub - el til sorg - er, tår - er og

**NB** noter  
This music is copyright protected



30

Fl. *f* *mf*

Cl. *f* *mf*

synth *f* *mf*

Accord. *f* *mf*

Vib.

kor+A  
blod. Sø - ke, le - te, hå - pe, els - ke, fin - ne. Hel - li - ge  
Hvert et Guds

kor+E  
blod. Sø - ke, le - te, hå - pe, els - ke, fin - ne. Hel - li - ge  
Hvert et Guds

Abd.  
blod. Sø - ke, le - te, hå - pe, els - ke, fin - ne. Hel - li - ge  
Hvert et Guds

Vln. A *f* *mf*

Vln.+div *f* *mf*

Vln. 1 *f* *mf*

Vln. 2 *f* *mf*

Vla. *f* *mf*

Vc. *f* *mf*

Cb. *f* *mf*

The image shows a page of a musical score for page 269. It includes staves for Flute (Fl.), Clarinet (Cl.), Synth, Accordion (Accord.), Vibraphone (Vib.), Choir A (kor+A), Choir E (kor+E), Abductor (Abd.), Violin A (Vln. A), Violin + Divisi (Vln.+div), Violin 1 (Vln. 1), Violin 2 (Vln. 2), Viola (Vla.), Violoncello (Vc.), and Contrabass (Cb.). The score starts at measure 30. Dynamics include *f* (forte) and *mf* (mezzo-forte). The vocal parts have lyrics in Danish: "blod. Sø - ke, le - te, hå - pe, els - ke, fin - ne. Hel - li - ge Hvert et Guds". A watermark "NB noter" is visible across the center of the page.

38

Fl.

Cl.

synth

Accord.

Vib.

kor+A

kor+E

Abd.

Vln. A

Vln.+div

Vln. 1

Vln. 2

Vla.

Vc.

Cb.

temp - ler, de fins i det fjer - ne. Pi - le-grims-mål - et kan søk - es opp med kjær - lig - het.  
 barn er en hjem - løs på jord - en, treng - er hver - and - re for var - me og for ver - ge.

temp - ler, de fins i det fjer - ne. Pi - le-grims-mål - et kan søk - es opp med kjær - lig - het.  
 barn er en hjem - løs på jord - en, treng - er hver - and - re for var - me og for ver - ge.

temp - ler, de fins i det fjer - ne. Pi - le-grims-mål - et kan søk - es opp med kjær - lig - het.  
 barn er en hjem - løs på jord - en, treng - er hver - and - re for var - me og for ver - ge.

*Watermark: NBNB noter. This music is copyright protected.*

45

Fl.

Cl.

synth

Accord.

Vib.

kor+A   
 Stolt skal vi la jas - min - en og ros - en er - ob - re ga - ter og sinn.  
 Der - for har Gud gitt kjær - lig-hets - bud - et til al - le A - bra-hams barn.

kor+E   
 Stolt skal vi la jas - min - en og ros - en er - ob - re ga - ter og sinn.  
 Der - for har Gud gitt kjær - lig-hets - bud - et til al - le A - bra-hams barn.

Abd.   
 Stolt skal vi la jas - min - en og ros - en er - ob - re ga - ter og sinn.  
 Der - for har Gud gitt kjær - lig-hets - bud - et til al - le A - bra-hams barn.

Vln. A

Vln.+div

Vln. 1

Vln. 2

Vla.

Vc.

Cb.

52

Fl. *ff* *mp*

Cl. *f* *p* *mp* bambusfl.

synth *f* *ff* synth.bass *mp*

Accord. *f* *mp*

Vib. *f*

kor+A *mp* Hvert et Guds

kor+E *mp* Hvert et Guds barn\_ skal

Abd.

Vln. A *f* *mp* går til posisjon i kirken

Vln.+div *f* *mp*

Vln. 1 *f* *mp*

Vln. 2 *f* *mp*

Vla. *f* *mp*

Vc. *f* *mp*

Cb. *f* *mp*





75

Fl.

Cl.

synth

Accord.

Vib.

kor+A

kor+E

Abd.

Vln. A

Vln.+div

Vln. 1

Vln. 2

Vla.

Vc.

Cb.

ff

piano

ff

f

hjel - pe, hvert et Guds barn skal hå - pe, hvert et Guds barn skal sø - ke, trøs - te,

hvert et Guds barn skal hå - pe, hvert et Guds barn skal hå - pe, els - ke, trøs - te,

barn skal hjel - pe, hvert et Guds barn skal hå - pe, hvert et Guds barn skal trøs - te,



83

Fl. *p mf*

Cl. *pmf*

synth *p mf*

*p*

Accord. *p mf*

Vib.

kor+A 3 - Kor; Alleluia  
hjel - pe, le - ve.

kor+E  
hjel - pe, le - ve.

Abd.  
hjel - pe, le - ve.

1 - Jødisk vuggesang

Vln. A

2 - Gresk vuggesang

Vln.+div

Vln. 1 *p mf*

Vln. 2 *p mf*

Vla. *p mf*

Vc. *p mf*

Cb. *p mf*

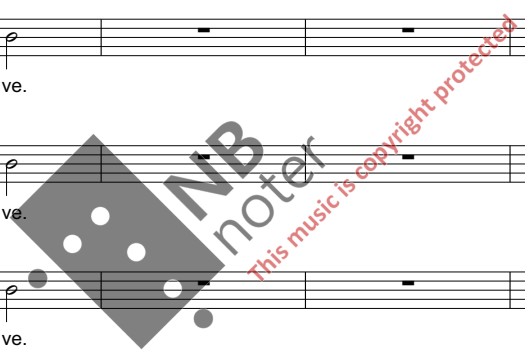





94

Fl.

Cl.

synth

Accord.

Vib.

kor+A

kor+E

Abd.

Vln. A

Vln.+div

Vln. 1

Vln. 2

Vla.

Vc.

Cb.

*NB noter*  
*this music is copyright protected*